

**HSM-WI7
Standun Bodymaker
High Speed Logic Module
User's Manual**

Systems Engineering Associates, Inc.
14989 West 69th Avenue
Arvada, Colorado 80007 U.S.A.
Telephone: (303) 421-0484
Fax: (303) 421-8108
www.sea-seg.com

02/2004

HSM-WI7
Standun Bodymaker
High Speed Logic Module
User's Manual

Copyright © 2001 Systems Engineering Associates, Inc.

All Rights Reserved!

Revised 16 February 2004

WARNING

To ensure the equipment described by this User Manual, as well as the equipment connected to and used with it, operates satisfactorily and safely, all applicable local and national codes that apply to installing and operating the equipment must be followed. This includes the National Electric Code in the USA and other applicable legislation, regulations, and codes in practice elsewhere. Since codes can vary geographically and can change with time, it is the user's responsibility to determine which standards and codes apply, and to comply with them.

FAILURE TO COMPLY WITH APPLICABLE CODES AND STANDARDS CAN RESULT IN DAMAGE TO EQUIPMENT AND/OR SERIOUS INJURY TO PERSONNEL.

Persons supervising and performing installation or maintenance must be suitably qualified and competent in these duties, and should carefully study this User Manual and any other manuals referred to by it prior to installation and/or operation of the equipment.

The contents of the User Manual are believed to be correct at the time of printing; however, no responsibility is assumed for inaccuracies. In the interests of a commitment to a policy of continuous development and improvement, the manufacturer reserves the right to change the specification of the product or its performance or the contents of the User Manual without notice.

Copyright © 2001 Systems Engineering Associates, Inc.

All Rights Reserved!

CONTENTS

1. General Description	1
1.1 Features	1
1.2 Functional Description	2
1.3 Clutch/Brake Control	3
1.3.1 Control of Clutch via Host PLC	4
1.4 Cupfeed/Rotary Feed Trip Solenoid Control	6
1.4.1 Control of Cupfeed Solenoid via Host PLC	6
1.4.2 Control of Rotary Trip Solenoid	7
1.5 Air Strip Control	7
1.6 Brake Wear Compensation	7
1.7 Alarm Detection	8
1.8 Data Collection	9
2. Installation	11
2.1 What's Included	11
2.2 Power Required	11
2.3 Mounting the HSM-WI7	12
2.4 Wiring the HSM-WI7	13
2.5 Mounting the RSV34-MS1 Resolver (if required)	14
2.6 HSM-WI7 Software Installation	15
2.6.1 Windows Based Setup Program Installation	15
2.6.2 DOS Based Setup Program Installation	16
2.6.3 SYSdev Program Development Software Installation	17
2.6.4 Application Program	17
2.7 Modify Existing PLC Program	18
2.8 HSM-WI7 Set-Up	19
2.8.1 Default Set-Up Variables	19
2.8.2 Set Bodymaker Set-Up Parameters	20
2.8.3 Set Trimmer Speed References	22
2.8.4 Set Machine Zero	22
2.8.5 Verify Location of Short Can Timing (CH02)	23
2.8.6 Verify Machine Operation	24
2.9 HSM-WI7 Module Replacement	26

CONTENTS

3. Using the Keypad/Display	29
3.1 Default Screen	30
3.2 "Brake Response" Key	30
3.3 "Last Shift" Key	31
3.4 "Set-up" Key	31
3.4.1 Set Bodymaker Parameters	33
3.4.2 Set Trimmer Parameters	34
3.4.3 Set Machine Timing (Set-Points, etc.)	35
3.4.4 Zero Machine (Set Resolver Offset)	37
3.5 Set Keypad/Display "Set-Up" Passcode	38
4. HSMWI7 Windows Based Set-up Program Reference	39
4.1 General Description	40
4.2 The File Menu	41
4.2.1 The Set-Up Data File	42
4.2.2 Upload (save) Data	44
4.2.3 Download Program	45
4.2.4 Download (restore) Data	46
4.2.5 Print Report	47
4.3 The Edit Menu	48
4.3.1 Enable Offline Editing	49
4.3.2 Setup Comm Port	49
4.3.3 Set-up Passcode	50
4.4 The View Menu	51
4.4.1 Target Board Interface	52
4.4.2 View Online Data	53
4.4.3 View Offline Data	53
4.5 The Window Menu	54
4.5.1 The Main Display Window	55
4.5.2 The Setup Parameters Window	56
4.5.3 The Machine Timing Window	60
4.5.4 The Shift Data Window	64
4.5.5 The I/O States Window	65

5. HSMWI7 DOS Based Set-up Program Reference	67
5.1 Set Bodymaker/Trimmer Set-up Parameters	68
5.1.1 Enable/Disable Brake Wear Compensation	68
5.1.2 Maximum Allowed B/M Stopping Response	69
5.1.3 Set Bodymaker Running Speeds	69
5.1.4 Set Trimmer Speed References	70
5.2 Set Machine Timing	71
5.2.1 Zeroing the Machine	72
5.2.2 Adjusting the Timing Channel Set-points	73
5.3 Shift Data/Brake Response	74
5.4 Download Program to Module	76
5.5 Download Set-up data to Module	77
5.6 Upload (Save) Set-up data from Module	78
6. General Timing Signal Locations	79
7. Recommended Spare Parts	81

CONTENTS

LIST OF FIGURES

Figure 1 - HSM-WI7 Recommended Panel Door Cut-out _____	12
Figure 2 - Short Can Check Timing Sequence _____	23
Keypad/Display Legend _____	29

APPENDICES

Drawings _____	Appendix A
----------------	------------

SECTION 1

GENERAL DESCRIPTION

This section describes the features of the HSM-WI7 Standun Bodymaker High Speed Logic module. This includes the functional description, alarms detected, interlocks between the module and the existing control system, etc.

1.1 FEATURES

- Performs the high-speed control functions of Standun Bodymaker to speeds in excess of 500 CPM. This includes clutch control, cupfeed control, air strip control, as well as die protection (short can detection).
- Rapid response control of clutch/brake system for emergency stops (die protection) as well as precise BDC stops. The clutch solenoid outputs of the HSM-WI7 are not intended as safety contacts for the bodymaker clutch and must not be the only interrupt to the clutch solenoids.
- Accurate short can detection to a resolution of 1/4" can length.
- Highly repeatable air strip control to reduce can stripping and blow out problems.
- Reliable timed cupfeed control to insure proper cup loading and protection from misloads.
- Brake Wear compensation (Auto BDC timing programming) algorithm to stop press at BDC regardless of brake response. Brake response determination allows displaying of actual brake response (in degrees). Brake response alarm to indicate when brake-stopping response (in degrees) has exceeded user preset limit.
- Trimmer speed reference (0-10volt analog output) provides reference to trimmer proportional to speed of bodymaker (user scalable).
- Alarm detection: short can detection, die sensor fail alarm, timing signal fail detection, clutch output failure detection, no ram motion alarm, resolver failure detection, and brake response too long alarm.

SECTION 1 GENERAL DESCRIPTION

- Data Acquisition: Total number of good cans produced and total number of short can faults (for both current shift and last shift).
- Built-in 2 Line X 40 character sealed display with 24 key membrane keypad allows local viewing of collected data (good can count, short can count, brake response) by operator and set-up of all user variables (passcode protected or key switch enabled) by authorized personnel.
- Interfaces directly with the machine-mounted resolver, short can sensor and all clutch, cupfeed, and air strip solenoids.
- Based on the high performance M4503 PLC/PLS module that allows easy trouble-shooting and user customization using SYSdev (DOS-based) programming package.
- Built-in PLS provides all machine timing, eliminating need for an additional PLS.

1.2 FUNCTIONAL DESCRIPTION

The HSM-WI7 bodymaker high-speed logic module is an electronic upgrade for the Standun bodymaker that performs the high-speed control functions of the bodymaker including: rapid response clutch/brake control, accurate short can detection, reliable cupfeed and precise air strip control. In addition, the package provides a brake wear compensation feature, which automatically adjusts the BDC timing signal to stop the press at BDC regardless of brake stopping time.

Alarm detection is provided including:

- Short Can Detection
- Die Sensor Failure Detection
- Timing Signal Failure
- Clutch Output Failure Detection
- No Ram Motion Alarm
- Resolver Failure Detection
- Brake Response Too Long Alarm

SECTION 1 GENERAL DESCRIPTION

Data collection includes (both for the current shift and previous (last) shift):

- Total Good Can Count
- Short Can Faults Count

The package interfaces directly to:

- The Machine Mounted Resolver
- Short Can Sensor
- Clutch/Brake
- Cupfeed and Air Strip Solenoids
- Host PLC via Discrete DC I/O.

The package is not a dedicated “black box”, but is instead implemented using the high performance SYSTEMS M4503 PLC/PLS module, which allows easy customization by either SEA or the end user. The M4503 module is programmed using the DOS-based SYSdev programming package, which allows the module to be programmed in any combination of Ladder or High-level (subset of “C”), as well as perform on-line monitoring and trouble-shooting. The M4503 module incorporates a built-in PLS which interfaces directly with the machine-mounted resolver and provides all machine timing, eliminating the need for an external PLS.

1.3 CLUTCH/BRAKE CONTROL

The clutch/brake solenoids are activated by the HSM-WI7 through the electro-mechanical two-hand control circuitry provided externally by the user. The throughput of the HSM-WI7 is 0.5 milliseconds. The fast throughput along with the fact that the PLS is fully integrated into the HSM-WI7, allows extremely fast and repeatable de-clutching and braking response to be achieved. Normally the clutch is controlled via inputs on the HSM-WI7 that are controlled from outputs on the host PLC. However, detection of any of the alarms (short can fault, die sensor failure, etc.) results in an immediate de-clutch of the solenoids.

SECTION 1

GENERAL DESCRIPTION

1.3.1 CONTROL OF CLUTCH VIA HOST PLC

Six discrete DC inputs to the HSM-WI7 from the host PLC are used to control the clutch: “Clutch On No.1”, “Clutch On No.2”, “Continuous Mode”, “Single Mode”, “Inch/Bar Mode”, and “Not Immediate Stop”. The HSM-WI7 is essentially a high speed gate which implements the BDC stop, sequenced stops closing the cupfeed, single, inch, and bar clutch control all based on the states of the six inputs listed above. The following description of operation defines the requirements of the host PLC logic to activate the clutch through the HSM-WI7:

Continuous Mode:

- 1) To activate the clutch in continuous mode, turn both the “Clutch On No.1” and “Clutch On No.2” inputs “on” simultaneously while the “Continuous Mode” and “Not Immediate Stop” inputs are “on”. The “Single” and “Inch/Bar” inputs must be “off”.
- 2) To perform a BDC stop, turn both the “Clutch On No.1” and “Clutch On No.2” inputs “off” while leaving the “Not Immediate Stop” input “on”.
- 3) To perform an immediate (emergency) stop, turn both the “Clutch On No.1” and “Clutch On No.2” as well as the “Not Immediate Stop” inputs “off” simultaneously. The “Not Immediate Stop” input is used to indicate to the HSM-WI7 that the clutch should be disengaged immediately, not waiting for the BDC timing signal.

Single Mode:

- 1) To single stroke the press, with the “Single Mode” and “Not Immediate Stop” inputs “on”, turn the “Clutch On No.1” and “Clutch On No.2” inputs “on” simultaneously for 5 to 50 milliseconds. The press will make one stroke. Both the “Continuous” and “Inch/Bar” mode inputs must be “off”.

SECTION 1 GENERAL DESCRIPTION

Inch Mode:

- 1) To inch the press, with the “Inch/Bar” mode and “Not Immediate Stop” inputs “on”, simultaneously turn “on” and “off” both the “Clutch On No.1” and “Clutch On No.2” inputs. The clutch is activated as long as both inputs are “on”. Both the “Continuous” and “Single” mode inputs must be “off”.

Bar Mode:

- 1) With both the “Inch/Bar Mode” and “Not Immediate Stop” inputs “on”, the clutch can be activated by simultaneously turning both the “Clutch On No.1” and “Clutch On No.2” inputs “on”. The clutch is activated as long as both inputs are “on”. Both the “Continuous” and “Single” mode inputs must be “off”.

Note: In all the above modes, the “Clutch On No.1” and “Clutch On No.2” inputs must be turned “on” simultaneously (within 0.5 seconds) in order for the clutch to activate.

Refer to the schematic at the back of this manual for typical HSM-WI7 clutch connections.

IMPORTANT SAFETY WARNING - The HSM-WI7 is intended as a high-speed logic gate to provide consistent and accurate clutch control. It is not designed as a redundant, dual-processor clutch brake safety module. The HSM-WI7 must not be the only means of controlling the bodymaker clutch mechanism. Good design practice dictates the use of safety interlocks on any device that starts or stops automatically that can cause personnel injury to operating or maintenance personnel. The HSM-WI7 must be used only in conjunction with industry approved safety interlock contacts, implemented in accordance with ANSI B11.1 safety requirements; otherwise, serious personnel injury may result.

SECTION 1 GENERAL DESCRIPTION

1.4 CUPFEED/ROTARY FEED TRIP SOLENOID CONTROL

The HSM-WI7 package provides control for both the cupfeed and rotary trip solenoids. Both are enabled by the host PLC via individual inputs to the HSM-WI7. The cupfeed is timed “on” and “off” with the cupfeed timing signal of the HSM-WI7 PLS section to provide accurate cup loading. The rotary trip solenoid is activated “on” and “off” by the host PLC but is immediately de-activated automatically by the HSM-WI7 at the detection of a short can.

1.4.1 CONTROL OF CUPFEED SOLENOID VIA HOST PLC

A discrete DC input to the HSM-WI7 from the host PLC is used to control the cupfeed solenoid: “Cupfeed On”. The following logic to activate the cupfeed through the HSM-WI7:

Cont/Single Mode:

- 1) In single and continuous modes, the cupfeed is gated “on” with the leading edge of the cupfeed timing signal (CH04) and gated “off” with the trailing edge of the cupfeed timing signal (CH04). The cupfeed is opened when the “Cupfeed On” input is turned “on” and the leading edge of CH04 occurs. The cupfeed is closed when the “Cupfeed On” input is turned “off” and the trailing edge of CH04 occurs.

Note: It takes two strokes once the cupfeed is opened for the first can to travel through the rotary cupfeed and punched. Once the cupfeed is closed, it requires two strokes to punch the last two cups, which are in process of traveling through the rotary cupfeed.

Inch Mode:

- 1) When the “Inch Mode” input is “on”, the cupfeed is controlled directly by the “Cupfeed On” input. When the “Cupfeed On” input is “on”, the cupfeed is open. When the “Cupfeed On” input is “off”, the cupfeed is closed.

1.4.2 CONTROL OF ROTARY TRIP SOLENOID

A discrete DC input to the HSM-WI7 from the host PLC is used to control the cupfeed solenoid: “Rotary Enable”. The rotary trip solenoid is controlled directly by the “Rotary Enable” input. When the input is “on”, the rotary cam is engaged. When the input is “off”, the rotary cam is disengaged. In addition, the rotary cam is automatically disengaged when a short can is detected.

1.5 AIR STRIP CONTROL

The HSM-WI7 provides a repeatability of 0.5 milliseconds for the air strip thus reducing can stripping and blow out problems. Both an “Air Strip (Low)” and “Air Strip (High)” timing signal is provided to activate the air strip when the press is running in low and high speed respectively. The air strip is enabled when the cupfeed is opened.

1.6 BRAKE WEAR COMPENSATION

The HSM-WI7 incorporates a brake wear compensation or automatic BDC timing feature that stops the press at BDC regardless of the actual braking response of the clutch/brake. The stopping sensation is accomplished by automatically adjusting the BDC timing signal based on the previous stop. Any overrun is detected and a new BDC timing signal is computed such that the machine will stop at the desired location on the next stop. Two BDC signals are provided: one for low speed and one for high speed. Both incorporate the brake wear compensation feature. The appropriate BDC timing signal (low or high) is adjusted based on the speed of the machine when the BDC stop was initiated.

In addition to the brake wear compensation, the HSM-WI7 also calculates the actual brake response (in degrees). This is the number of degrees from where the clutch was de-activated (BDC timing location) to where the crankshaft actually ended up stopping. This can then be displayed by the operator or maintenance personnel to determine the condition of the brake.

SECTION 1 GENERAL DESCRIPTION

A “Brake Response Too Long” alarm is also generated when the actual brake response exceeds a user specified maximum allowed brake response. This can be used to indicate that service to the brake should be performed.

1.7 ALARM DETECTION

The package detects the following alarms:

Short Can Detection: The “Short Can Check” timing signal (CH02), along with the machine mounted short can sensor, is used to verify the entire length of the can. The short can sensor must see can the entire time the “Short Can Check” timing signal (CH02) is “on”. If the can is short (tear off) or any void is detected, the short can alarm is generated. The clutch is immediately de-activated as well as the cupfeed and rotary trip solenoids. The resolution of the short can check is 0.5 milliseconds. At a machine speed of 250CPM, this translates to approximately 1/4” resolution in can length.

Die Sensor Failure: This alarm occurs when the short can sensor fails “on”. The “Sensor Check” timing signal (CH03) is used to verify that the short can sensor does indeed turn “off” when a can is not present.

Timing Signal Fail: The timing signal fail occurs when any of the timing signals generated in the PLS section fail to change state periodically while the machine is running.

Clutch Output Fail (No.1/No.2): These alarms occur when the respective clutch output (no.1 or no.2) fails either “on” or “off”. This indicates either a failure in the outputs of the S4568 board that drives the clutch or a short circuit or open circuit in the clutch output wiring.

No Ram Motion Detected: This alarm occurs when the clutch is activated and no ram motion is detected after a time delay. This could indicate either the clutch did not activate or that a failure in the resolver coupling has occurred.

SECTION 1 GENERAL DESCRIPTION

Resolver Fault - Motion Detected at Stop: This alarm occurs when motion is detected after the clutch has been disengaged for a time delay. This indicates either a broken wire in the resolver cable or a failure in the resolver windings.

Brake Response Too Long: The “Brake Response Too Long” alarm is generated when the actual brake response exceeds a user specified maximum allowed brake response. This can be used to indicate that service to the brake should be performed.

The “Short Can Alarm” is available to the host PLC as a discrete output. The balance of the alarms is summed together into the “Not HSM Alarm” discrete output. If any one these alarms occur the “Not HSM Alarm” is turned “off”. If all alarms are cleared, the “Not HSM Alarm” is “on”. These two outputs should be interlocked to the existing control system to disable the clutch logic. The respective alarm message is displayed on the HSM-WI7 Keypad/Display when the corresponding alarm is active.

1.8 DATA COLLECTION

The following data is collected for both the current shift and the previous (last) shift:

- 1) Total Number of Good Cans Produced
- 2) Total Number of Short Can Faults

This data can be viewed locally on the Keypad/Display. This information is updated (“current” shift transferred to “Last” shift) based on the change of state of the “End of Shift” input.

SECTION 1
GENERAL DESCRIPTION

(This Page Intentionally Left Blank)

SECTION 2 INSTALLATION

The HSM-WI7 module is provided for door mounting on the existing user's control cabinet door or console.

2.1 WHAT'S INCLUDED

Verify that the following items are included when unpacking the HSM-WI7:

- 1ea. HSM-WI7 M4503 Module with required I/O boards
- 1ea. HSM-WI7 User's Manual
- 1ea. HSM-WI7 Keypad Quick Reference
- 1ea. M4500 User's Manual
- 1ea. HSM-WI7 Program Disk

The following items are optional items and can be purchased separately as required or desired:

- 1ea. RSV34-MS1 Resolver
- 1ea. RSV-RSCBLE-XX Resolver Cable

2.2 POWER REQUIRED

The HSM-WI7 is powered from 115/230VAC 50/60HZ and +24VDC. The 115/230VAC is used to power the HSM-WI7 module while the +24VDC is used to power the +24VDC I/O (sensors, clutch solenoids, etc.).

Note: +24VDC solenoids must be used for all clutch, cupfeed, and air strip solenoids. These provide a much more consistent and repeatable response time than 115VAC solenoids. Assuming +24VDC solenoids were used in the existing system, the +24VDC current required by the HSM-WI7 is no more than the existing systems +24VDC current requirement therefore the existing +24VDC power supply should be adequate.

SECTION 2 INSTALLATION

2.3 MOUNTING THE HSM-WI7

The HSM-WI7 module should be mounted in the door of the existing user's cabinet or console door. Perform the following steps to mount the HSM-WI7 module:

- 1) Referring to the recommended cut-out in figure 1, cut a cut-out in the door of the existing user's control cabinet or console.
- 2) Remove the all the field wiring connectors from the top of the HSM-WI7 module. With the gasket installed on the HSM-WI7 module mounting studs, slide the HSM-WI7 module into the cut-out from the front. Attach the HSM-WI7 module to the door using the supplied hardware.
- 3) Once the module is installed, a lugged earth ground wire should be installed on one of the module mounting screws to insure that the HSM-WI7 is well grounded.

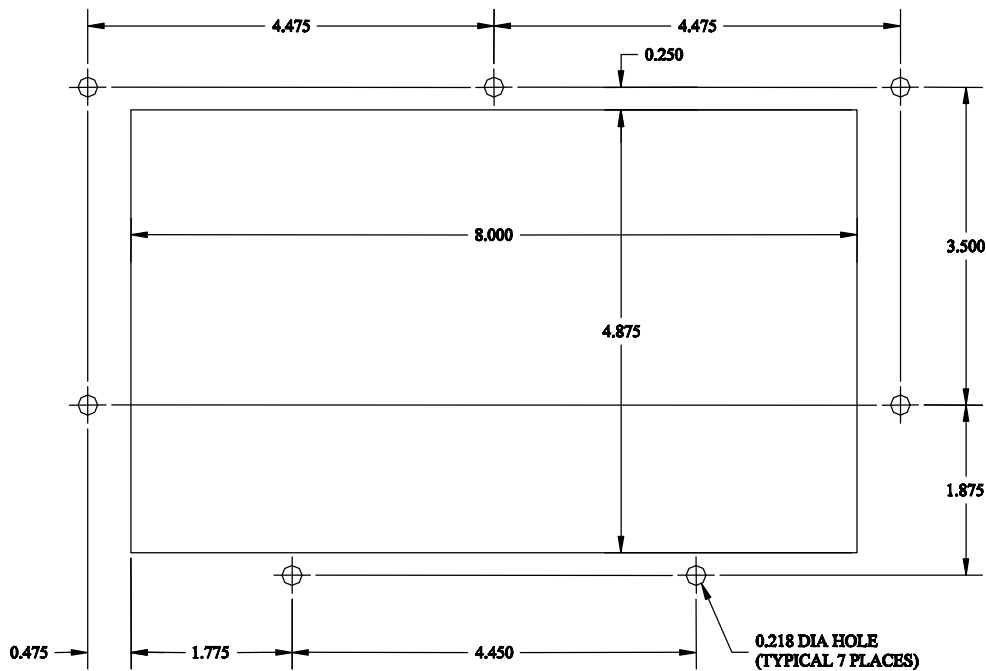

Figure 1 - HSM-WI7 Recommended Panel Door Cut-out

2.4 WIRING THE HSM-WI7

Referring to the electrical control schematic at the back of this manual, wire the HSM-WI7 as follows:

Note: The HSM-WI7 contains removable field wiring connectors for ease of maintenance. It is generally easier to perform the wiring described below with the connectors removed from the module and then installing the connectors to the module once all wiring is complete.

- 1) Incoming Power, (115VAC-230VAC to L, N, and G of HSM-WI7 power connector and +24VDC to I/O connectors).
- 2) Interlocks from existing control system to HSM-WI7 (inputs B100.0, B100.1, B100.2, B100.3, B100.4, B100.5, B100.6, B100.7, and B101.2).
- 3) Interlocks to existing control system from HSM-WI7 (outputs B110.5, B110.6, and B110.7).
- 4) Clutch, Cupfeed, Rotary Trip, and Air Strip solenoids.
- 5) Short Can Sensor using three conductor shielded cable. The shield of the sensor cable should be tied to earth ground at a terminal inside the existing control cabinet and left floating at the sensor.
- 6) Set-Up Enable (passcode by-pass) key switch (if desired).
- 7) Resolver cable from resolver or existing PLS to RO-S4 connector on HSM-WI7 using a three pair, two conductor shielded cable. The shield of the resolver cable should be tied to the “SHLD” terminal of the HSM-WI7 resolver input connector. Make sure the resolver cable shield is left floating at the resolver.
- 8) Trimmer Speed reference (0-10V analog) from HSM-WI7 to trimmer drive (if used).

Note: In some applications it may be necessary to use an analog isolation amplifier (not provided) to isolate the drive from the HSM-WI7 module to prevent damage to the HSM-WI7 module.

SECTION 2 INSTALLATION

In general, when wiring the HSM-WI7, keep all +24VDC wiring, resolver cable, and trimmer speed reference wiring away from high voltage wiring.

2.5 MOUNTING THE RSV34-MS1 RESOLVER (IF REQUIRED)

The HSM-WI7 is designed to interface to a resolver (not encoder) for machine timing. If the machine is not already equipped with a resolver, then the existing encoder will have to be removed and an RSV34-MS1 resolver will have to be mounted in its place. If this is the case, refer to the RSV34-MS1 data sheet for details on mounting the resolver. Use the RSV-RSCBLE cable to connect the resolver to the HSM-WI7. Route the resolver cable in a separate conduit, away from all other high voltage and control wiring. Wire the cable directly to the 8-pin resolver connector on the HSM-WI7 (see section 2.4).

2.6 HSM-WI7 SOFTWARE INSTALLATION

The HSM-WI7 set-up software is used to

- Download the Program to the HSM-WI7 Module
- Tune (Set-Up) the User Adjustable Variables of the HSM-WI7
- Download and Upload (Save) the User Set-Up Variables to Disk
- View Shift Data

Follow the steps below to install either the Windows or DOS based setup programs and PLC application program on a PC used to support the HSM-WI7 control system.

2.6.1 WINDOWS™ BASED SET-UP PROGRAM INSTALLATION

The HSMWI7 setup program is compatible with Windows 95/98/ME/2000/XP operating systems.

To install the set-up software, perform the following steps:

- 1) Insert the HSM-WI7 CD into the drive
- 2) From the Windows desktop, “Click” Start and then select run.
- 3) From the “Run” dialog box, “Click” the Browse button.
- 4) Select the drive with HSM-WI7 CD. Select the “setup.exe” file and “Click” Open and then Ok.
- 5) This will initiate the installation process. Follow the instructions that appear on the screen to complete the installation process. The HSMWI7 setup program can be executed from the “Systems” folder located in Programs.

SECTION 2 INSTALLATION

2.6.2 DOS BASED SET-UP PROGRAM INSTALLATION

To install the DOS based set-up software perform the following steps:

- 1) Create one directory off the root directory of the PC for each bodymaker. These will be used to store the "HSMWI7.EXE" setup programs and HSMWI7 set-up data for each bodymaker.

Create these directories by typing the following at the DOS prompt:

```
MD \HSMWI1<ENTER>
MD \HSMWI2<ENTER>
MD \HSMWI3<ENTER>
etc.
```

- 2) Install the "PROGRAMS" disk into the drive. For each "HSMWI" directory created, switch to that directory and install the "HSM-WI7" set-up programs by typing the following at the DOS prompt (bodymaker #1 is shown):

```
CD \HSMWI1<ENTER>
A:INSTALL<ENTER>
```

- 3) Add each bodymaker's HSM-WI7 set-up program to your computer's menu software by creating a selection for each bodymaker called "SET-UP W/I #1" for bodymaker #1, "SET-UP W/I #2" for bodymaker #2, etc.. The DOS commands executed for these selections should be (bodymaker #1 shown):

```
For the "SET-UP W/I #1" selection:
CD \HSMWI1
HSMWI7 HSMWI7
CD \
```

- 4) To execute the respective bodymaker's set-up program, simply select the corresponding "SET-UP W/I" selection from the menu software's menu.

2.6.3 SYSdev PROGRAM DEVELOPMENT SOFTWARE INSTALLATION

The SYSdev Program Development software is used to perform on-line trouble-shooting and program modifications to the HSM-WI7. If SYSdev was purchased with the HSM-WI7 package and is not already installed on your computer, install SYSdev onto the hard drive of your computer following the steps in the SYSdev Program Development manual.

2.6.4 HSM-WI7 APPLICATION PROGRAM INSTALLATION

The application program is a SYSdev based program, loaded into the M4500 module and performs the HSM-WI7 logic. The program is written in a combination of Ladder logic and High-level. If the user desires to make program changes or perform on-line monitoring of the program execution the files, which constitute the HSMWI7 program, will have to be loaded onto the hard drive of the PC used to support the system. The SYSdev Program Development Software will also have to be loaded on the PC. To install this program perform the following:

- 1) Install the "PROGRAMS" disk into the drive.
- 2) For each of the "HSMWI7" directories (created in section 2.6.2), copy all the files from the disk to each of these subdirectories.

SECTION 2 INSTALLATION

2.7 MODIFY EXISTING PLC PROGRAM

Modify the existing control system PLC program to interface with the HSM-WI7 by incorporating the following into the existing PLC ladder logic:

- 1) The HSM-WI7 now controls the clutch BDC stop, cupfeed, air strip, and short can detection. Defeat the existing short can detection in the PLC. Add the “Short Can Alarm” input from the HSM-WI7 and the “No HSM Alarm” interlock.

Note: These two alarms must be immediately disable the clutch logic in the PLC. The “Short Can Alarm” is true logic (“on” when alarm detected) while the “No HSM Alarm” is inverted logic (“off” when alarm is detected).

- 2) Add the “Clutch On No.1” and “Clutch On No.2” outputs into the PLC logic. In general, these can be derived from the logic that use to drive the clutch solenoids by removing the BDC timing signal from the original logic.
- 3) Add the “Continuous”, “Single”, and “Inch/Bar” Mode outputs to the existing PLC logic. The respective output should be “on” when the corresponding mode is selected.
- 4) Add the “Not Immediate Stop” output to the PLC logic. This should be “on” when no E-stop or immediate stop condition is present and turn “off” as soon as either condition occurs. In general, the clutch control as interfaced with the above six interlocks, should be implemented as defined in section 1.3.
- 5) Add the “Cupfeed On” output into the PLC program. In continuous and single modes, this signal should be the summation of the cupfeed auto mode and all line control stand-by conditions (when “on”, the cupfeed will be timed opened by the HSM-WI7 when the machine is running and feed cups in the normal production mode). In inch mode, the cupfeed will be opened when this output is “on”.
- 6) Add the “Rotary Enable” output to the PLC program. This must be “on” to enable the rotary cam in normal production.

- 7) Add the “Alarm Reset” output. This signal should be “on” as long as the system reset push-button is depressed.

2.8 HSM-WI7 SET-UP

The HSM-WI7 is shipped from the factory with the PLC program “HSMWI7” loaded in the PLC section of the HSM-WI7 module and the PLS channel set-point file “WI7TMG” loaded in the PLS section. In most cases, the following user variables and timing channels may have to be altered to tune the HSM-WI7 to the actual bodymaker it is controlling.

Once the HSM-WI7 is installed and the control system is powered back up, perform the following to set-up and tune the HSM-WI7. The set-up is performed using the Display/Keypad of the HSM-WI7 or a PC running the “HSMWI7” set-up program. See section 3 for a description of the Keypad commands and menu displays of the HSM-WI7 Display/Keypad. See section 4 for a description of the menus, variables and how to use the Windows based set-up program. See section 5 for a description of the menus, variables and how to use the DOS based set-up program.

2.8.1 DEFAULT SET-UP VARIABLES

As shipped, the user variables for the HSM-WI7 are set to the following defaults:

Brake Wear Compensation:

Enabled _____ : N
Desired BDC Stop Position (Low Speed) _____ : 000
Desired BDC Stop Position (High Speed) _____ : 000

Maximum Allowed Stopping Response (degrees) _____ : 300

Bodymaker Running Speeds:

Low Speed (SPM) _____ : 250
High Speed (SPM) _____ : 350

Trimmer Speed Reference:

Maximum Speed _____ : 375
Idle Speed (W/I stopped) _____ : 250
High Speed Offset _____ : 20

SECTION 2 INSTALLATION

The “WI7TMG” timing channel file, as shipped, contains the following default timing set-points:

CHAN	ON - OFF	DESCRIPTION
CH00:	150 - 170	BDC (high) Timing
CH01:	180 - 200	BDC (low) Timing
CH02:	155 - 175	Short Can Check Timing
CH03:	110 - 130	Sensor Check Timing
CH04:	230 - 300	Cupfeed Timing
CH05:	150 - 200	Air Strip (low) Timing
CH06:	120 - 190	Air Strip (high) Timing
CH07:	180 - 000	PLC Clock Timing
CH10:	000 - 030	Motion (“on” for 30, “off” for 30 thru-out)
CH11:	___ - ___	spare
CH12:	___ - ___	spare
CH13:	___ - ___	spare
CH14:	___ - ___	spare
CH15:	___ - ___	spare
CH16:	___ - ___	spare
CH17:	___ - ___	spare

2.8.2 SET BODYMAKER SET-UP PARAMETERS

The Bodymaker set-up parameters include: enabling or disabling the brake wear compensation, setting the desired low and high speed stopping points (if the brake wear compensation is enabled), setting the maximum allowed stopping response, and setting the bodymaker running low and high speeds.

Brake Wear Compensation: If the brake wear compensation is to be used, enable it by setting the “Brake Wear Compensation Enable” to “Y”. Set the “Desired BDC Stop Position (Low)” and “(High)” as well if the compensation is enabled. The “Desired BDC Stop positions” are the location you want the ram to be at when it comes to rest after a BDC stop. Both the “Low” and “High” desired stopping positions are generally set to 000 degrees. Enabling the brake wear compensation allows the HSM-WI7 to automatically adjust the BDC timing channels (CH00-High) and (CH01-Low) as necessary such that the press will stop at the desired stopping position regardless of the actual brake response.

SECTION 2 INSTALLATION

If the brake wear compensation is not to be used, disable it by setting the “Brake Wear Compensation Enable” to “N”. Disabling the brake wear compensation requires the BDC (High) timing (CH00) and the BDC (Low) timing (CH01) signals to be set manually such that the press stops at BDC.

Note: If the brake response then changes, the press will not stop at the desired position if the brake wear compensation is disabled.

Maximum Allowed Stopping Response: This parameter defines what the maximum allowed brake response is before the “Brake Response Too Long” alarm is generated. If the actual brake response (number of degrees from when the brake is activated to the position where the press ends up at rest) when a BDC stop is performed is longer than this number, the alarm is generated. If the actual brake response is less, the alarm is not generated. Set this parameter to the value where the brake response is considered too long and service to the brake should be performed (typically 270 to 300 degrees).

Bodymaker Running Speeds: Set the Bodymaker running “Low Speed” and “High Speed” to the speeds that the bodymaker will actually run at when the respective speed is selected.

Note: This is not a speed reference that will make the bodymaker run at the speeds entered but is instead simply parameters used by the HSM-WI7 to know when to switch between the BDC (Low) and BDC (High) timing as well as the Air Strip (Low) and (High) timing etc.

See section 3.4 (HSM-WI7 Keypad/Display) or section 4 (Windows based set-up program) or section 5 (DOS based set-up program) for details on setting the above set-up parameters.

SECTION 2 INSTALLATION

2.8.3 SET TRIMMER SPEED REFERENCES

Set the “Trimmer Maximum Speed”, “Trimmer Idle Speed”, and “Trimmer High Speed Offset” as desired. These three parameters are used to actually control the speed of the trimmer (via the 0-10VDC trimmer speed reference output of the HSM-WI7 module).

Trimmer Maximum Speed: The “Trimmer Maximum Speed” parameter is used to scale the 0-10VDC analog output such that when the bodymaker is running at the speed entered in “Trimmer Maximum Speed”, the analog output will be at 10 volts.

Trimmer Idle (Minimum) Speed: This parameter determines the speed the trimmer will run at when the bodymaker is stopped (de-clutched).

Note: When the bodymaker is running, the trimmer speed reference is proportional (as set by the “Trimmer Maximum Speed” scaling) to the speed of the bodymaker. This parameter is used to provide the speed reference when the bodymaker speed is zero.

Trimmer High Speed Offset: This parameter is used to modulate the speed of the trimmer as a function of cans present at the infeed of the trimmer. A high infeed sensor can be added to the trimmer infeed such that the trimmer will run at the bodymaker running speed plus the “Trimmer High Speed Offset” value. This allows the trimmer to speed up when the infeed to the trimmer backs-up and slow down once the trimmer runs the cans out.

See section 3.4 (HSM-WI7 Keypad/Display) or section 4 (Windows based set-up program) or section 5 (DOS based set-up program) for details on setting the above set-up parameters.

2.8.4 SET MACHINE ZERO

Inch the bodymaker to back dead center (BDC) and set the HSM-WI7 resolver offset per section 3.4 (HSM-WI7 keypad) or section 4 (Windows based set-up program) or section 5 (DOS based set-up program).

2.8.5 VERIFY LOCATION OF SHORT CAN TIMING (CH02)

By inching the machine, verify that the “Short Can” timing (CH02) of the HSM-WI7 first turns “on” when the short can sensor is over the nose of the punch on the forward portion of the stroke (see figure 2). This would be where the sensor would first “see” the can as it emerges from the die set. Verify that the “Short Can” timing turns “off” right before the sensor would quit seeing the lip of the can as the ram continues it's forward motion. Adjust either or both of the turn “on” or turn “off” locations of CH02 until the above is achieved. Depending on the location of the short can sensor, CH02 is typically set “on” at 155 degrees and then back “off” at 175 degrees.

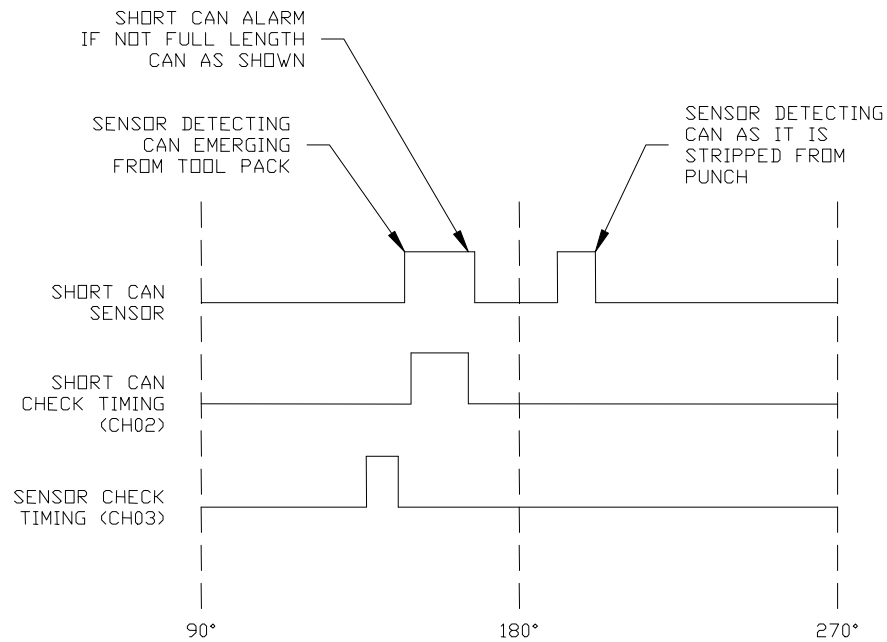

Figure 2 - Short Can Check Timing Sequence

SECTION 2 INSTALLATION

Note: The short can sensor must “see” can the entire time the “Short Can” timing (CH02) is “on” in order to pass the short can check. Otherwise, the “Short Can” alarm will be generated.

At this time, also verify that the “Sensor Check” timing (CH03) is also set correctly. This timing signal should go “on” for 20 degrees then back “off” just prior to the punch emerging from the die set (typically 110 to 130 degrees). This signal is used to verify that the short can sensor has not failed “on” and therefore the short can sensor must be “off” the entire time CH03 is “on” otherwise the “Die Sensor Fail” alarm is generated.

See section 3.4 (HSM-WI7 Keypad/Display) or section 4 (Windows Based set-up program) or section 5 (DOS Based set-up program) for details on setting CH02 and CH03.

2.8.6 VERIFY MACHINE OPERATION

Once steps 2.8.2 thru 2.8.5 are complete, run the machine in normal production (both at low and high speeds where practical) and verify the following:

Verify Air Strip Timing: With the machine running, with the cupfeed open, verify that the cans are stripped with-out any problems and that no blow-outs are occurring (verify at both low and high speed if a problem is occurring, adjust the respective “Air Strip” timing (CH05-Low Speed, CH06-High Speed) until the problem is corrected. See section 3.4 (HSM-WI7 Keypad/Display) or section 4 (Windows based set-up program) or section 5 (DOS based set-up program) for details on adjusting CH05 and CH06.

Verify Short Can Timing: With the machine running with the cupfeed open, verify that no false short can faults are occurring (short can alarm occurs when full length can is made). If false short can alarms are occurring, narrow the short can timing one degree at a time until the false short can alarms quit occurring.

SECTION 2 INSTALLATION

Verify that the short can detection is working correctly by generating a short can and verifying that the short can alarm is generated for this can. This can be done by stopping the press, removing one of the die rings then punching a cup in single stroke mode with the die ring removed. The short can alarm should be generated when the first cup is punched.

Verify BDC Stops: If the brake wear compensation is enabled, verify that the press does stop at the desired location in both the high and the low speeds.

Note: When the HSM-WI7 is first installed, it will take a few successive stops for the algorithm to program the BDC timing channels to the correct position. Also, the compensation is enabled after the press has been running at a fixed speed in continuous. The BDC timing channels will not be modified when single strokes are made or if press is started in continuous and then immediately stopped again. Wait about 5 seconds after the press is started before performing the BDC stop to verify the stop position.

If the brake wear compensation is disabled, manually adjust both the BDC (High) timing (CH00) and the BDC (Low) timing (CH01) such that the press stops at back dead center at both respective speeds. See section 3.4 (HSM-WI7 Keypad/Display) or section 4 (Windows based set-up program) or section 5 (DOS based set-up program) for details on adjusting CH00 and CH01.

The Machine Is Now Set-Up and Ready To Run.

SECTION 2 INSTALLATION

2.9 HSM-WI7 MODULE REPLACEMENT

The following is provided only as a reference. These steps need only be performed in the event the HSM-WI7 module needs to be replaced once installed. To replace the module, perform the following:

- 1) Turn both 115VAC and +24VDC power to the module “off” and remove all the field wiring connectors from the module.
- 2) Remove the 8-32 nuts and lock washers (7ea.) which retain the module in the door and remove the module.
- 3) Remove the supplied field wiring connectors from the new module and install the new module in the door cut-out from the front and re-install the 8-32 nuts and lock washers (7ea).
- 4) Install the existing pre-wired field wiring connectors on all the I/O boards of the module (115VAC power connector, I/O slots0 and 1, resolver connector, and IN0/IN1 connector). Make sure all the field wiring connectors are fully mated in the module.
- 5) Apply 115VAC and +24VDC power to the module and verify that the “PWR” and “RUN” LEDs on the module are “on” and the “FLT” LED is “off”.
- 6) Connect an RS-232 cable from the computer COM port to the “PROG” port on the HSM-WI7.
- 7) From the computer's menu program, select the respective bodymaker's “SET-UP W/I” selection (this was set in section 2.6.2). The “HSMWI7” set-up program will be invoked with the corresponding HSMWI7 application program for that bodymaker.
- 8) Download the PLS timing set-points to the module by selecting “2: Machine Timing” from the HSM-WI7 main menu. From the PLS main development menu, select “4: Download Channels to PLS”. Press the <ENTER> key to start the download. Press any key to return back to the PLS main development menu. Press 12<ENTER> to return back the HSM-WI7 main menu.

SECTION 2 INSTALLATION

- 9) Download the previously saved to disk set-up data to the module by selecting “5: Download Set-up data to Module” from the HSM main menu. Press the <ENTER> key to start the download. Once the download is complete, press any key to return to the HSM-WI7 main menu. See section 5.5 for complete details.
- 10) The HSM-WI7 is now ready to run, loaded with the HSMWI7 timing set-points, and set-up data that was previously saved for the respective bodymaker. Press <ESC> to return back to the computer's menu software program.

SECTION 3 USING THE KEYPAD/DISPLAY

The keypad of the HSM-WI7 contains 24 keys consisting of data display commands, set-up commands, and a numeric keypad. The display of the HSM-WI7 is a 2 line by 40 character back-lit LCD display which displays the selected data and set-up menus. The keypad/display can be used by the operator to view data or can be used to adjust the timing and all set-up parameters.

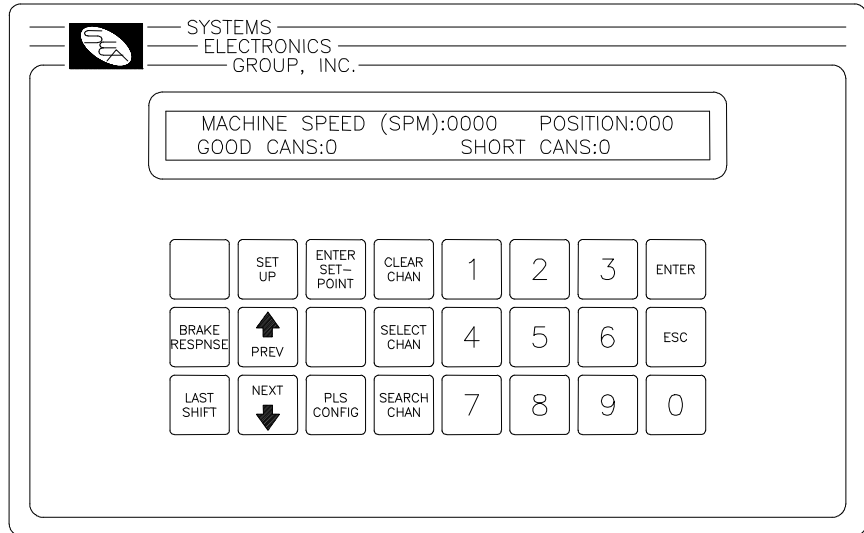

The display/keypad allows the following to be viewed or adjusted:

- 1) Set the Bodymaker Set-Up Parameters
- 2) Set the Trimmer Set-Up Parameters
- 3) Set Machine Timing
- 4) Set Machine Zero
- 5) View the Actual Brake Response (in degrees)
- 6) View the Current Shift Data
- 7) View the Last Shift Data

The definitions of the keypad commands and menus are described in the following sections.

Note: For virtually all the menus, the “NEXT” and “PREV” keys can be used to advance to the next item of the menu or retard to the previous item on the menu.

SECTION 3 USING THE KEYPAD/DISPLAY

3.1 DEFAULT SCREEN

The default screen (displayed when no other commands are active) contains the following data:

MACHINE SPEED (SPM):xxxx POSITION:xxx
GOOD CANS:xxxxxxx SHORT CANS:xxxxxx

Where:

- The “Machine Speed” is the Current Speed of the Bodymaker
- The “Position” is the Current Angular Position of the Bodymaker Crankshaft
- The “Good Cans” Field is the Total Number of Good Cans Produced so Far Into the Current Shift
- The “Short Cans” Field is the Total Number of Short Can Faults the Machine has had so Far into the Current Shift

This display effectively replaces a speed meter, a position display, and two can counters. This screen is always returned to when no commands are active.

3.2 “BRAKE RESPONSE” KEY

This key displays the brake response of both low speed and high speed stops. The response is the number of degrees it takes the press to stop from when the clutch is de-activated for a BDC stop to the position that the machine comes to rest. This can be used to determine the general condition of the brake and whether servicing of the brake is required. To exit back to the default screen, simply press the “ESC” key.

SECTION 3 USING THE KEYPAD/DISPLAY

3.3 “LAST SHIFT” KEY

The Last shift data menu displays the “Total Good Can” count and the “Total Short Can” fault count. This data is the totals for the last (previous) shift. This data is transferred from the current shift to the “Last shift” data when the end of shift input transfers from a “0” to a “1”. This can be at the end of either an 8 or 12 hour shift. This data is only reset at the end of shift transition.

Note: The Current shift “Good Cans” and “Short Cans” is displayed as part of the default screen.

The Last shift data is defined as follows:

Good Cans: This is the total number of good cans produced for the previous shift. This is essentially a can counter.

Short Cans: This is the total number of short can faults the machine had the previous shift.

3.4 “SET-UP” KEY

This selection is used to invoke the primary set-up menu. This consists of the following four selections:

- 1: SET BODYMAKER PARAMETERS
- 2: SET TRIMMER PARAMETERS
- 3: SET MACHINE TIMING (SET-POINTS, ETC.)
- 4: ZERO MACHINE (SET RESOLVER OFFSET)

When selected, each of the above selections brings up a sub-menu with the corresponding set-up parameters. The following sections describe these sub-menus and the definitions of the corresponding variables. To select the respective set-up sub-menu, simply press the corresponding numeric key (1 thru 4).

SECTION 3 USING THE KEYPAD/DISPLAY

Note: The primary set-up menu is passcode protected. When the set-up key is first depressed, an “ENTER PASSCODE:” prompt is displayed. A 5-digit passcode must be entered followed by pressing the <ENTER> key. If the passcode entered is correct, the primary set-up menu is then displayed and any of the parameters accessed by this menu may be changed. If the passcode entered is incorrect, the message “INCORRECT PASSCODE” will be displayed. At this time the passcode may be entered again or the <ESC> key can be pressed to return back to the main menu.

When the passcode is entered, the digits entered are not displayed. Instead “*” characters are displayed as each digit is entered. This prevents unauthorized personnel from observing the passcode as it is entered. In addition, the “ENTER PASSCODE” prompt is only displayed for a maximum of 60 seconds. The correct passcode must be entered within this 60 second period otherwise the set-up mode is aborted and the main menu is re-displayed.

Refer to section 3.5 (Set Keypad/Display “Set-up” passcode) for details on setting the passcode as desired.

For user's that would prefer to use a keyed switch to prevent unauthorized access instead of a passcode, the “Set-Up Enable” input can be used. When this input is “on”, the passcode prompt is bypassed and access to the primary set-up menu is provided immediately. If the “Set-Up Enable” input is “off”, then the normal passcode prompt is displayed. A keyed switch can then be wired to the “Set-Up Enable” input such that when the switch is in the enable position, the input is “on”.

The “NEXT” and “PREV” keys can be used to advance to the next parameter or the previous parameter respectively. To change the currently displayed parameter, simply enter the new value on the numeric keypad and press <ENTER>. The value will be entered and the next parameter will automatically be displayed. When the last parameter is entered, the primary set-up menu is again displayed. Pressing <ESC> at anytime will also exit you back to the primary set-up menu.

3.4.1 SET BODYMAKER PARAMETERS

This menu is activated when the “1” key (SET BODYMAKER PARAMETERS) is pressed while the primary set-up menu is active. The following four set-up parameters may then be adjusted or viewed:

Brake Wear Comp Enable? (0=No, 1=Yes): This prompt is used to enable or disable the brake wear compensation. If the compensation is to be disabled, enter “0” and press <ENTER>. If the compensation is to be enabled, enter “1” and press <ENTER>.

Desired BDC Stop POS (Low Speed): This is the desired stopping location (in degrees) for a BDC stop in low speed when the brake wear compensation is enabled. This is typical set to 000 degrees (Back Dead Center). This prompt is only displayed when the brake wear compensation is enabled.

Desired BDC Stop POS (High Speed): This is the desired stopping location (in degrees) for a BDC stop in high speed when the brake wear compensation is enabled. This is typical set to 000 degrees (Back Dead Center). This prompt is only displayed when the brake wear compensation is enabled.

Maximum Allowed Stopping Response: This defines what the maximum allowed brake response is before the “Brake Response Too Long” alarm is generated. If the actual brake response (number of degrees from when the brake is activated to the position where the press ends up at rest) when a BDC stop is performed is longer than this number, the alarm is generated. If the actual brake response is less, the alarm is not generated. Set this parameter to the value where the brake response is considered too long and service to the brake should be performed (typically 270 to 300 degrees).

Running Bodymaker Low Speed (SPM): This is the speed (in strokes per minute) the bodymaker will run when in low speed.

Running Bodymaker High Speed (SPM): This is the speed (in strokes per minute) the bodymaker will run when in high speed.

SECTION 3 USING THE KEYPAD/DISPLAY

3.4.2 SET TRIMMER PARAMETERS

This menu is activated when the “2” key (SET TRIMMER PARAMETERS) is pressed while the primary set-up menu is active. The following trimmer set-up parameters may then be adjusted or viewed:

Trimmer Maximum Speed (CPM): The “Trimmer Maximum Speed” parameter is used to scale the 0-10VDC analog output such that when the bodymaker is running at the speed entered in “Trimmer Maximum Speed”, the analog output will be at 10 volts. This is typically set to the running high speed of the Bodymaker or slightly higher.

Trimmer Minimum Speed (CPM): This parameter determines the speed the trimmer will run at when the bodymaker is stopped (de-clutched).

Note: When the bodymaker is running, the trimmer speed reference is proportional (as set by the “Trimmer Maximum Speed” scaling) to the speed of the bodymaker. This parameter is used to provide the speed reference when the bodymaker speed is zero.

Trimmer High Speed Offset: This parameter is used to modulate the speed of the trimmer as a function of cans present at the infeed of the trimmer. A high infeed sensor can be added to the trimmer infeed such that the trimmer will run at the bodymaker running speed plus the “Trimmer High Speed Offset” value. This allows the trimmer to speed up when the infeed to the trimmer backs-up and slow down once the trimmer runs the cans out.

SECTION 3 USING THE KEYPAD/DISPLAY

3.4.3 SET MACHINE TIMING (SET-POINTS, ETC.)

This selection brings up the timing set-point menu which displays the following fields:

CHuu SETPOINT:xxx [] "channel name"
RPM:yyyy POS:zzz OFFSET:www SCALE:360

Each field is defined as follows:

<u>Field</u>	<u>Definition</u>
Chuu	Currently selected channel (CH00 thru CH17) where "uu" is the octal channel number.
SETPOINT:xxx	Channel "on" or "off" set-point where "xxx" is the set-point position
[]	State of channel set-point (blank = "off", solid block character = "on")
"channel name"	selected channel name: (CH00) BDC (HIGH) TIMING, (CH01) BDC (LOW) TIMING, etc.
RPM:yyyy	Current machine speed where "yyyy" is in CPM.
POS:zzz	Current resolver position where "zzz" is in degrees.
OFFSET:www	Resolver offset where "www" is the offset in degrees.
SCALE:360	Resolver SCALE FACTOR (360 degrees per revolution).

In addition to displaying the timing set-point menu, the following keys are also enabled: "ENTER SET-POINT", "CLEAR CHANNEL", "SELECT CHANNEL", and "SEARCH CHANNEL".

SECTION 3 USING THE KEYPAD/DISPLAY

The “ENTER SET-POINT” key is used to enter a new set-point (both “on” and “off” set-points) in the selected channel. The “CLEAR CHANNEL” key is used to clear all set-points from the selected channel. The “SELECT CHANNEL” key is used to select a new channel for programming. The “SEARCH CHANNEL” is used to view both the “on” and “off” set-points in the selected channel.

Searching Channel: To view the set-points in a channel simply press the “SEARCH CHANNEL” key. The next “off” to “on” or “on” to “off” position is shown in the “SETPOINT” field. If the transition was “off” to “on”, the state character [] will be a solid block. If the transition was “on” to “off”, the state character [] will be blank.

Entering or Adjusting Set-point: To set or adjust a timing channel, perform the following:

- 1) Select the channel to be adjusted by pressing the “SELECT CHANNEL” key, entering the channel number (00 to 17) and pressing <ENTER>. In addition, the “NEXT” and “PREV” keys can be used to advance to the next channel or retard to the previous channel.
- 2) Press “CLEAR CHANNEL” to clear the existing set-point out.

Note: Entering a new set-point does not automatically clear the old set-point out. If the two set-points are not in the same place, the channel will simply have two set-points in it if the old one is not cleared out first. Therefore, always clear the channel before entering a new set-point. A set-point may, however, be “extended” by programming another set-point onto an existing set-point using either the existing “on” or “off” set-point as the starting position for the new set-point. This will result in one larger set-point.

- 3) Press “ENTER SET-POINT” to enter the new set-point. The display will then prompt “ON SETPOINT:”. Enter the position (in degrees) where the set-point should go “on” and press <ENTER>. The display will now prompt “OFF SETPOINT:”. Enter the position (in degrees) where the set-point should go “off” and press <ENTER>. The channel will now be programmed with a set-point that goes “on” at the “on” position entered and “off” at the “off” position entered.

SECTION 3 USING THE KEYPAD/DISPLAY

- 4) Exit back to the primary set-up menu by pressing <ESC>. Exit back to the default screen by pressing <ESC> again.

3.4.4 ZERO MACHINE (SET RESOLVER OFFSET)

This selection is used to auto zero the resolver. To set the machine zero (resolver offset) perform the following:

- 1) Select “3: SET MACHINE TIMING” and observe the “POS:” field. Verify that as the machine is rotated forward (either inched or barred) that the position increases linearly from 0 through 359. If not, swap the S1 and S3 leads of the resolver at the HSM-WI7 resolver connector. Then verify that the position then indeed does increase with forward movement. Press <ESC> to exit back to the primary set-up menu.
- 2) Position the machine at machine zero (back dead center).
- 3) Auto zero the resolver by selecting “4: ZERO MACHINE” from the primary set-up menu. Enter “0” to zero the resolver. The timing set-up menu will be displayed, now showing the “POS:” at zero.
- 4) The HSM-WI7 will calculate the actual offset value required to make this the 000 position and will display this number in the offset field.
- 5) Exit back to the primary set-up menu by pressing <ESC>. Exit back to the default screen by pressing <ESC> again.

SECTION 3 USING THE KEYPAD/DISPLAY

3.5 SET KEYPAD/DISPLAY “SET-UP” PASSCODE

The “Set Passcode” input to the HSM-WI7 is used to actually set or view the passcode of the set-up menu. Normally this input should be “off”. When the passcode is to be set, jumper this input to +24VDC and press the “Set-Up” key. The “ENTER PASSCODE” prompt will be displayed and the current 5-digit passcode will be displayed with the prompt. This allows the passcode to be viewed if necessary.

If the passcode is to be changed, enter any number between 0 and 64999 and press <ENTER>.

Note: If passcode protection is not to be used, set the passcode to “0”. Then when the passcode is prompted for after the “Set-up” key is pressed, simply press <ENTER> to proceed to the set-up menu. If the passcode protection is used, set the passcode to a number between 1 and 64999. Then when the “Set-up” key is pressed, the actual valid passcode number will have to be entered in order to gain access to the set-up menu.

Once the passcode is set, turn the “Set Passcode” input back “off”. The set-up menu will be passcode protected with the number you have entered as the passcode.

SECTION 4 HSMWI7 WINDOWS BASED SET-UP PROGRAM REFERENCE

The Windows based set-up program is menu driven, allowing the user to easily view data, alter set-up variables or set machine timing (resolver offset, timing signal locations, etc.), using a PC running the Windows (95/98/ME/2000/XP/NT) operating system. The set-up variables are used to configure and tune the M4500 to match the configuration and performance of the specific bodymaker (see HSM-WI7 Set-up, section 2.8).

Note: The set-up program is an on-line communications program used to interface with the M4500 module. The data displayed and set in the windows is communicated directly to the module, while in the “Online” edit mode. Therefore, prior to going online with the processor, make sure an RS-232 cable is connected from the COM port on the computer to the "PROG" port on the M4500. The variables displayed while in the “Online” edit mode are read directly from the processor. Data is saved to a “Set-up Data” file (*.sdt) whenever changes are made to a parameter or if the data is uploaded from the processor.

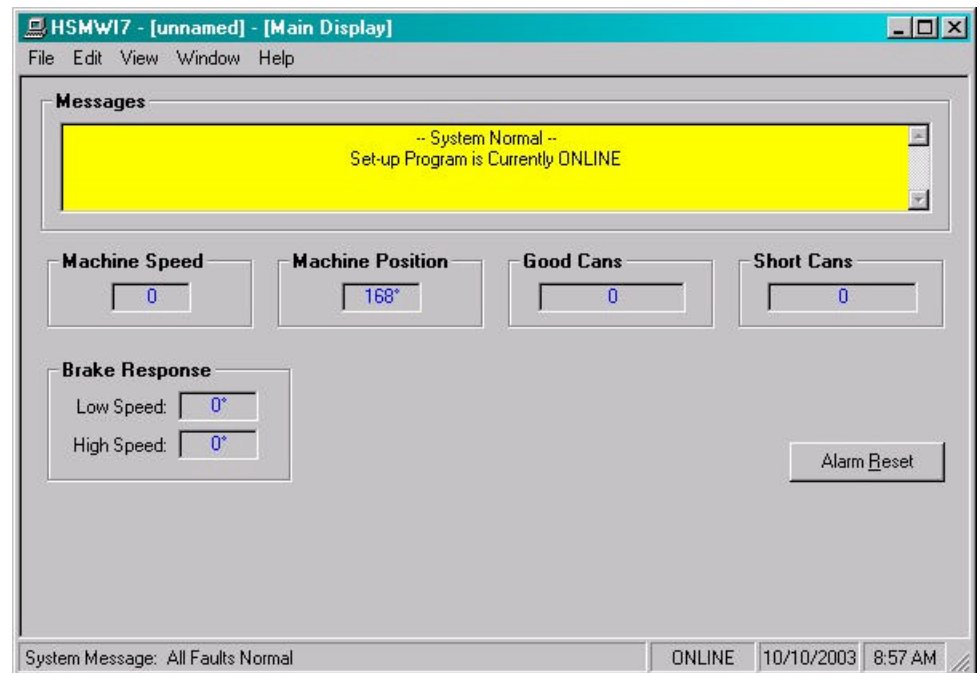

SECTION 4

HSMWI7 WINDOWS BASED SET-UP PROGRAM REFERENCE

4.1 GENERAL DESCRIPTION

Title Bar: At the top of the window is the “Title Bar”. The title bar is used to display the name of the working “Set-up Data” file, as well as, the name of the active “Window”. The title bar is dark if the window is active and grayed if another window is active. The color depends on the settings of the Display Properties of the Control Panel.

Status Bar: At the bottom of the window is the “Status Bar”. The status bar is used to display system messages, online or offline mode, as well as, the current time and date as set by the operating system. The system messages panel displays general information about operation of the system. The Online/Offline mode panel displays the status of the current set-up program mode of operation. The mode of operation can be changed by simply double clicking the online/offline mode panel.

Hot Keys: Hot keys are activated by holding down the “ALT” key and simultaneously pressing the underlined letter of the desired function. Almost every function can be activated by either pressing a series of hot keys or using the “TAB” key to move between fields.

Online/Offline Modes: The set-up program allows the user to make changes while “Online” with the processor. The “Offline” mode is used to preset parameters prior to download. All functions are available to the user while “Online”, however, specific “Online” functions are disabled in the “Offline” edit mode.

Note: Offline changes can only be made by enabling “Offline Editing”, accessed from the “Edit” menu.

Getting Help: The entire contents of the user’s manual is contained within the help file. Pressing Ctrl+H will display the help file window. Pressing the F1 key will display the contents file. Hot spots allow jumps to other topics to display additional information as desired. Selecting “About HSMWI7” from the Help menu will display a dialog box listing information about the current revision of the setup program and how to obtain technical support.

SECTION 4 HSMWI7 WINDOWS BASED SET-UP PROGRAM REFERENCE

4.2 THE FILE MENU

The “File” menu allows the user to perform the following functions:

- Create a “New” set-up “Data File”.
- Open an existing “Data File”.
- Save any changes made to the current “Data File” to disk.
- Upload (save) Data from the Processor.
- Download a SYSdev (.sdv) program to the processor
- Download (restore) Data from the current set-up “Data File” to the processor
- Print a Report of the current set-up parameters.
- Exit the set-up program

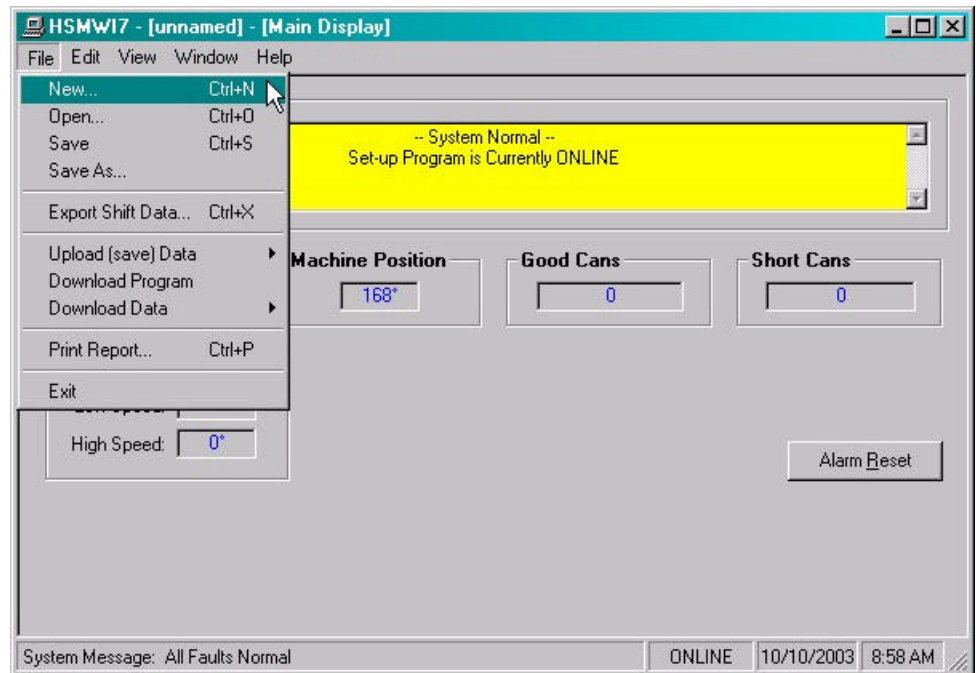

SECTION 4

HSMWI7 WINDOWS BASED SET-UP PROGRAM REFERENCE

4.2.1 THE SET-UP DATA FILE

The set-up “Data File” (.sdt) is a binary access file, designed for fast file I/O operation. When the set-up program is first invoked, the default set-up parameters are loaded into memory. If changes are made to any of the set-up parameters (either online or offline), as well as shift data, the user will be flagged to “Save Changes” upon exit of the program.

Note: Any windows based “Set-up” program can open a set-up “Data File”, however, the data tables will not be properly aligned. The user will be alerted to the problem if a set-up data file has been created by either a different set-up program or a different revision of the software.

The set-up “Data File” is similar to that of a word processing file. When the program first starts, a default file is loaded and the user is able to make any changes as desired. The set-up program is unaware of the settings and parameters that exist within the M4500. Therefore, to normalize the set-up program with the processor, the user should define or open an existing file, then upload “All” variables from the processor. This allows the user to either create a backup of the data or maintain an existing file. The user can even open a data file for another bodymaker, save the file to a new name, make the necessary changes and simply download the new parameters to another processor.

The following functions can be accessed any time, from any set-up or display windows.

New: To create a “New” data file, select “New” from the “File” menu or press “Ctrl + N”. This creates a completely new file, loaded with the default variables and the word “[unnamed]” is displayed in the title bar. If any changes were made to the existing file, the user is prompted to save changes to the existing file.

Open: To “Open” and existing data file, select “Open” from the “File” menu or press “Ctrl + O”. This displays a dialog box allowing the user to select an existing data file to open. The name of the file will be displayed in the title bar. If any changes were made to the existing file, the user will be prompted to save any changes before terminating the program.

SECTION 4

HSMWI7 WINDOWS BASED SET-UP PROGRAM REFERENCE

Save: To “Save” data file to disk, select “Save” from the “File” menu or press “Ctrl + S”. This displays a dialog box allowing the user to select a folder and enter a name for the file. The user will be notified if the file already exists and the extension “.sdt” will automatically be added to the file name. If this is a “New” file, the user will be prompted to enter a file name.

Save As: To save the data file to a new name, select “Save As” from the “File” menu.. This displays a dialog box allowing the user to select a folder and enter in a new name for the file. The user will be notified if the file exists and the extension “.sdt” will automatically be added to the file name.

Export Shift Data...: This function allows the user to export the shift data to a “Tab Delimited” text file. This allows the user to easily use the shift data to produce production reports.

SECTION 4 HSMWI7 WINDOWS BASED SET-UP PROGRAM REFERENCE

4.2.2 UPLOAD (SAVE) DATA

The “Set-up” program allows the user to upload set-up parameters, timing channel set-points and shift data from the M4500 into a set-up “Data File”. This function is accessed from the “File” menu and the user is given the choice of the following options:

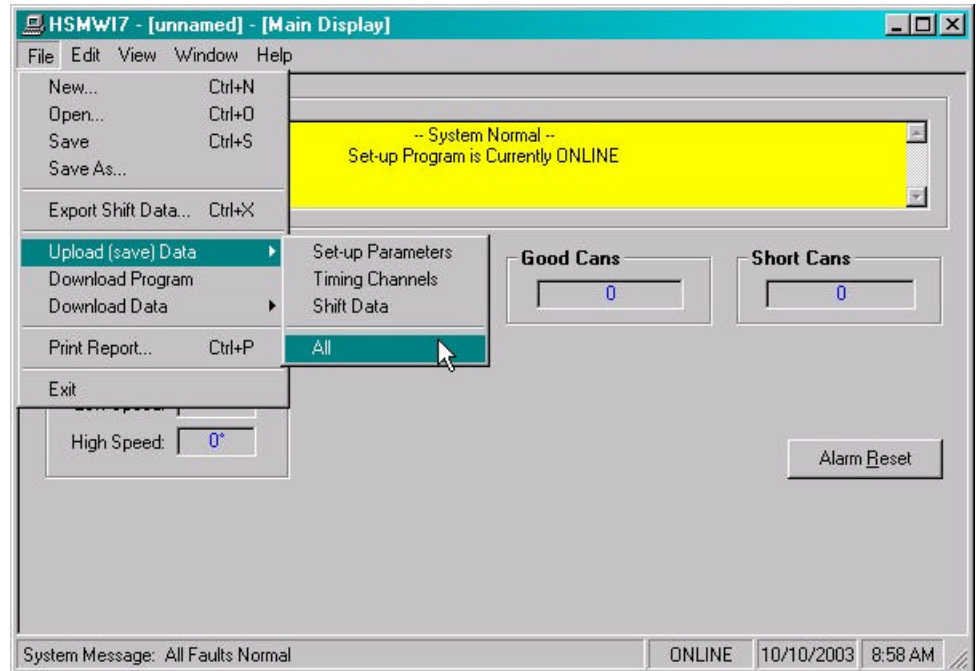

Set-up Parameters: This option uploads the “Set-up” data from the M4500. This includes bodymaker and trimmer set-up parameters.

Timing Channels: This option uploads the “Machine Timing” channel set-points, as well as, the PLS configuration and scale factor.

Shift Data: This option uploads the “Shift Data” from the M4500. This includes the total good cans and total short cans for both the current and last shifts.

All: This option allows the user to completely upload “All” of the set-up parameters, timing channel set-points and shift data from the M4500.

SECTION 4 HSMWI7 WINDOWS BASED SET-UP PROGRAM REFERENCE

4.2.3 DOWNLOAD PROGRAM

The “Set-up” program allows the user to “Download” any SYSdev program file to the M4500.

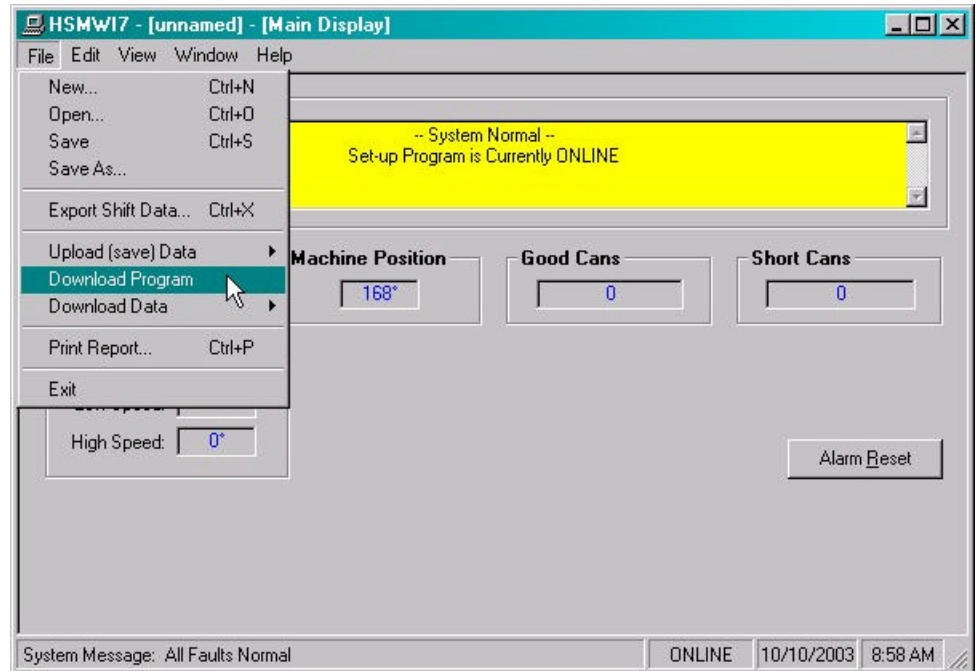

Note: To “Download” a SYSdev program to the processor, the program must be “Online”. If “Online” mode cannot be achieved, program download will not be executed. If the program is currently “Offline”, the user will be prompted to first go “Online”.

Once selected, and the set-up program “Online” with the processor, a dialog box will be displayed, allowing the user to select the SYSdev file to download.

Note: Only the files with the “.sdv” file extension will be displayed. It is important to keep in mind that only a valid M4500 PLC SYSdev file can be downloaded through the set-up program. Care should be taken when selecting a program to download.

SECTION 4 HSMWI7 WINDOWS BASED SET-UP PROGRAM REFERENCE

Once selected, a message box is displayed informing the user of the current program, revision and checksum of the program loaded in the processor, as well as, that of the selected program. The user must confirm their selection by clicking the “Yes” command button. After the user confirms their choice, program download is initiated and the current program download address is displayed. When program download is complete, the user is prompted to acknowledge. Control is passed back to the main program and the set-up program remains in an “Online” edit mode.

4.2.4 DOWNLOAD (RESTORE) DATA

The set-up program allows the user to download “Set-up” parameters, timing channel set-points and shift data to the M4500 from the set-up “Data File”. This function is accessed from the “File” menu and the user is given the choice of the following options:

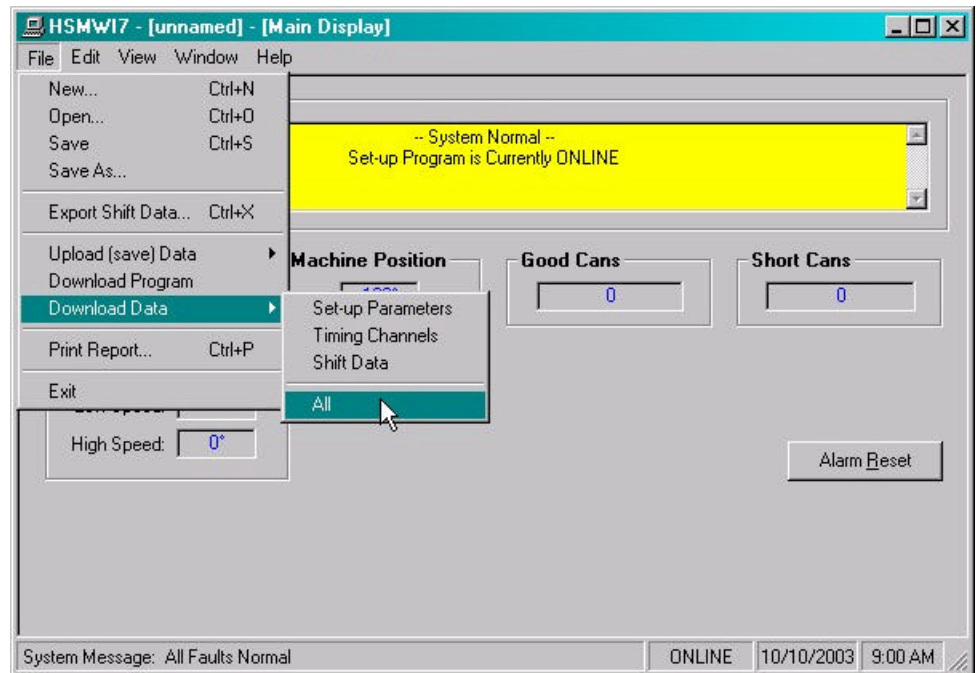

Set-up Parameters: This option downloads the “Set-up” data to the M4500. This includes bodymaker and trimmer set-up parameters.

SECTION 4

HSMWI7 WINDOWS BASED SET-UP PROGRAM REFERENCE

Timing Channels: This option downloads the “Machine Timing” channel set-points, as well as the PLS configuration and scale factor to the M4500 PLS.

Shift Data: This option downloads the “Shift Data” to the M4500. This includes the total good cans and total short cans for both the current and last shifts.

All: This option allows the user to completely download “All” of the set-up parameters, timing channel set-points and shift data to the M4500.

Note: Only the values contained within the current data file are used. If the validity of the current data file is questionable, review the data in an “Offline” mode prior to download.

4.2.5 PRINT REPORT

The “Set-up” program allows the user to generate a “Report” printout of all the set-up parameters, timing channel set-points and shift data. This function is accessed from the “File” menu.

At the top of each page, the report displays the name of the set-up file being printed. At the bottom of each page is the date and time the document was printed, as well as, the page number.

To printout a report of the settings contained in the set-up “Data File”, perform the following:

- 1) From the “File” menu, select “Print Report” or press “Ctrl + P”. This displays the “Print Setup” dialog box, allowing the user to select a printer, as well as, the paper size and orientation. Once the user selects “OK”, the report is generated and sent to the specified printer device. This function makes use of the windows print manager, which allows the user to continue with their work while the document is being printed.

SECTION 4

HSMWI7 WINDOWS BASED SET-UP PROGRAM REFERENCE

4.3 THE EDIT MENU

The “Edit” menu allows the user to perform the following functions:

- Enable/Disable Offline Editing.
- Set-up the Comm Port.
- Set the Set-up Passcode

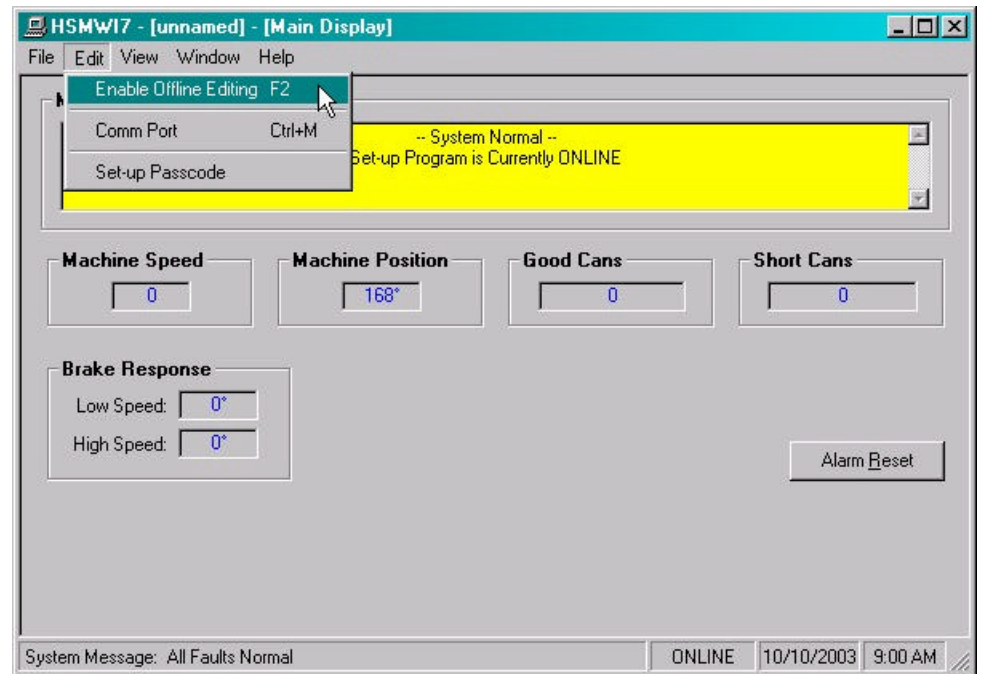

SECTION 4

HSMWI7 WINDOWS BASED SET-UP PROGRAM REFERENCE

4.3.1 ENABLE OFFLINE EDITING

This function allows the user to perform “Offline” editing on the currently loaded set-up data file. This allows the user the ability to make any necessary changes to the set-up parameters while not online with the processor.

If offline editing is not enabled, the user is only able to view the set-up parameters and shift data. When the program is first invoked, the default setting is offline editing disabled. The user will need to specifically select “Enable Offline Editing” from the edit menu (or press function key F2) to enable/disable this feature.

4.3.2 SETUP COMM PORT

This function allows the user to specify the serial communications port and baud rate to talk to the M4500. The programming port of the M4500 is set to 9600 baud.

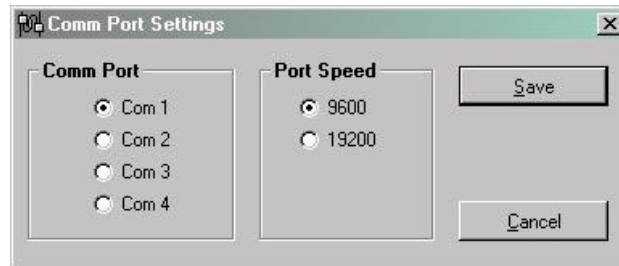

Once selected, a dialog box requesting the user to select a “Comm Port” and “Baud Rate” will be displayed. The default setting is COM1 at 9600 baud. The option to select the 19200 baud rate is to allow the user to communicate with the processor via the S4516 serial communications board.

In most cases the user will only need to specify the communications port and leave the baud rate at 9600. If communication problems occur, make sure there is a secure connection from the PC to the PLC. Then check the Comm port. In most cases the user will only need to select a new Comm port. If communication problems persist there may be another program causing a conflict with the port. Check the port configuration from the “Settings” folder.

SECTION 4

HSMWI7 WINDOWS BASED SET-UP PROGRAM REFERENCE

4.3.3 EDIT SET-UP PASSCODE

The edit “Set-up Passcode” is an “Online” function only. This allows the user the ability to directly change the value of the “Set-up Passcode”. The passcode is not included as part of the setup data file.

Once selected, an input box is displayed, allowing the user to view the current “Passcode” setting and to change the value if necessary. If the passcode is set to zero, passcode entry is disabled. The operator can press the Set-up key on the Keypad/Display and simply press the <ENTER> key to gain access to the set-up parameters without having to enter a zero.

If the value of the passcode is a value between 1 and 65,000, “Passcode Entry” is enabled. This requires the operator to enter in the “Correct” passcode to gain access to the set-up parameters.

Note: Passcode entry is only in effect when the “Set-up Enable” selector switch is in the “Disable” position.

If an invalid value is entered, the passcode value will not be reset and a message box notifying the user of the error is displayed.

SECTION 4 HSMWI7 WINDOWS BASED SET-UP PROGRAM REFERENCE

4.4 THE VIEW MENU

The “View” menu allows the user to perform the following functions:

- View the “Target Board Interface”
- View “Online” Data
- View “Offline” Data

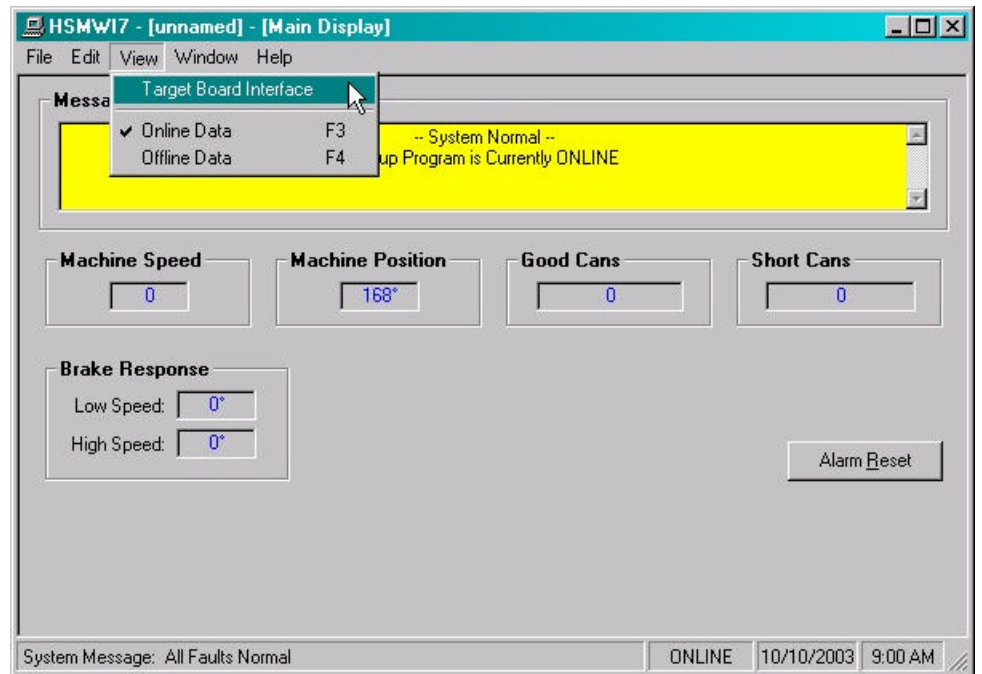

SECTION 4

HSMWI7 WINDOWS BASED SET-UP PROGRAM REFERENCE

4.4.1 TARGET BOARD INTERFACE

This function allows the user to view fault codes, S3000 network communication error codes and review the current “Ident” and “Revision” of the application program. This is accessed by the “View” menu, by selecting “Target Board Interface”.

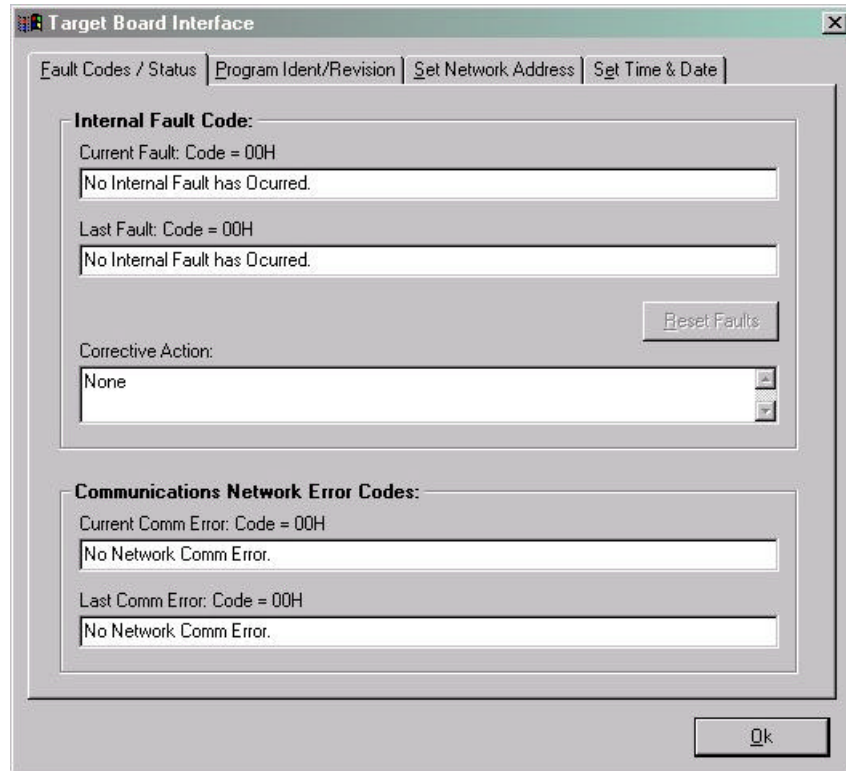

Once invoked, the set-up program will prompt the user to select a program to compare with the one existing in the processor. Whether a program is selected or the user cancels, the setup program will attempt to communicate with the M4500. If unsuccessful, a warning message will be displayed, prompting the user to either “Retry” or “Cancel” the operation. If the operation is canceled and communication with the processor cannot be established the system will be placed in an “Offline” mode, however the “Target Board Interface” window will still be displayed.

SECTION 4

HSMWI7 WINDOWS BASED SET-UP PROGRAM REFERENCE

4.4.2 VIEW ONLINE DATA

This function allows the user to place the set-up program in an “Online” mode with the processor. This is accessed by the “View” menu, by selecting “Online Data” or by simply pressing the “F3” function key.

Note: The program can be toggled between “Offline” and “Online” by simply double clicking on the “Online” or “Offline” panel displayed in the status bar at the bottom of the window.

Once invoked, the set-up program will attempt to open the Comm port and communicate with the M4500. If the set-up program is unsuccessful, a warning message will be displayed prompting the user to either “Retry” or “Cancel” the operation. If the operation is canceled and communication with the processor cannot be established the system will be placed in an “Offline” edit mode.

Note: Anytime while the set-up program is “Online” with the processor and communication is interrupted, a warning message will be displayed, prompting the user to either “Retry” or “Cancel” the operation.

4.4.3 VIEW OFFLINE DATA

This function allows the user to place the set-up program in an “Offline” mode. This is accessed by the “View” menu, by selecting “Offline Data” or by simply pressing the “F4” function key. This allows the user to perform “Offline” editing. All values displayed in “Offline” edit mode reflect the actual values contained in the currently loaded set-up data file.

Note: The program can be toggled between “Online” and “Offline” by simply double clicking on the “Online” or “Offline” panel displayed in the status bar at the bottom of the window.

Once invoked, the set-up program will close the Comm port and cease communication with the M4500.

SECTION 4 HSMWI7 WINDOWS BASED SET-UP PROGRAM REFERENCE

4.5 THE WINDOW MENU

The “Window” menu allows the user to select one of 5 different Display/Set-up windows to modify set-up parameters, view shift data or receive feedback about the current status of the control system.

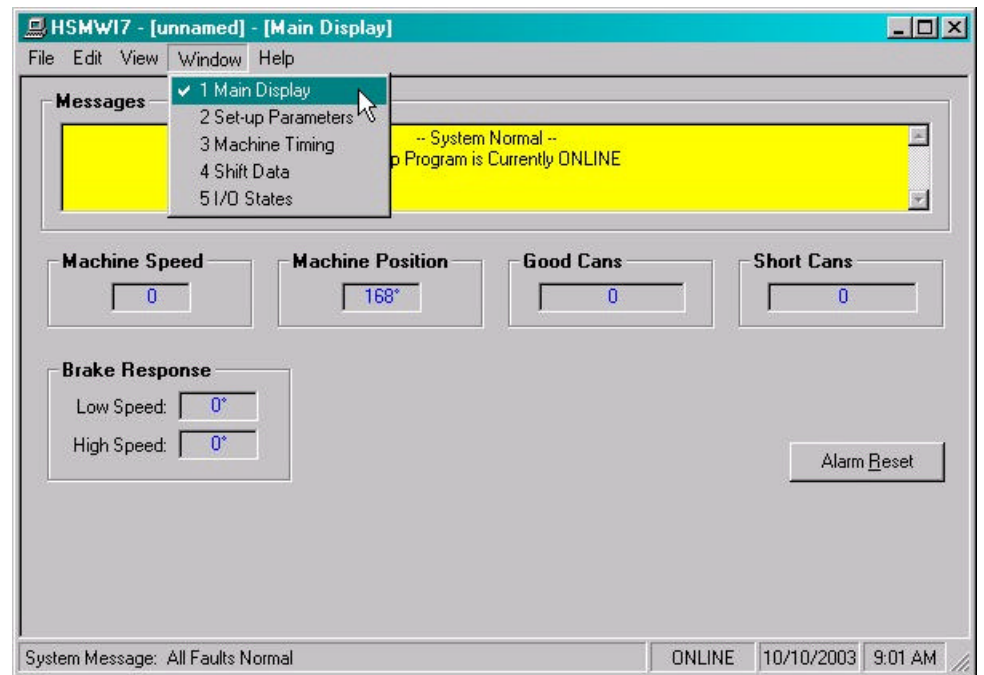

Once a window menu item is selected, a check mark is placed next to the selected item and the selected window is displayed with the name changed in the title bar of the main window.

Note: “Read” only variables are displayed in blue with a gray background. Any variables that can be altered by the user are displayed in black with a white background. In most cases, a parameter that can be changed by the user will have associated with it increment and decrement controls. The user can either click on the desired parameter to adjust and enter in a new value, or use the increment or decrement controls to change the value by 1 unit.

SECTION 4 HSMWI7 WINDOWS BASED SET-UP PROGRAM REFERENCE

4.5.1 THE MAIN DISPLAY WINDOW

The “Main Display” window is used to display the general state of the control system. This window is selected from the “Window”.

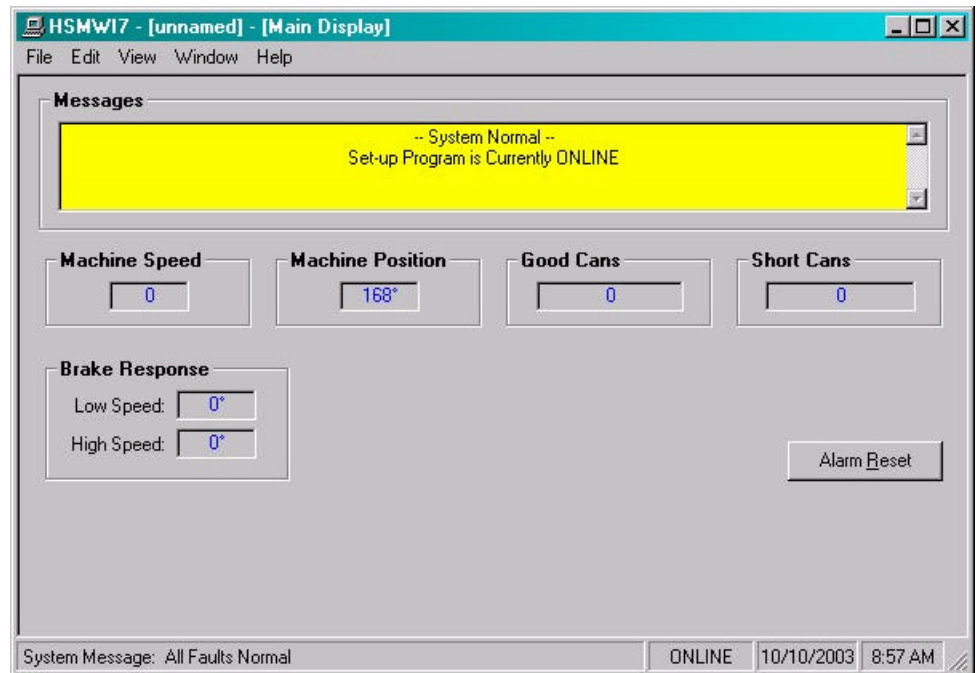

The following is a list of the functions of the “Main Display” window.

Messages: The “Messages” display is continuously updated. It displays alarm and status messages specific to the M4500, as well as, the current “Online” or “Offline” status of the set-up program. By simply scrolling the display, the user is able to view all active alarm and status messages. If no alarm or status messages are active, a default message is displayed.

Machine Speed: This display is only active while “Online” and displays the current speed of the machine in “Strokes Per Minute”.

Position: This display is only active while “Online” and displays the current angular position of the Bodymaker crankshaft.

Good Cans: This display is the “Current Shift” total number of good cans so far into the current shift.

SECTION 4

HSMWI7 WINDOWS BASED SET-UP PROGRAM REFERENCE

Short Cans: This display is the “Current Shift” total number of short can faults that the machine has had so far into the current shift.

Brake Response: This is the brake response of both the low and high speed stops. The response is the number of degrees it takes the press to stop from when the clutch is de-activated for a BDC stop to the position that the machine comes to rest.

4.5.2 THE SETUP PARAMETERS WINDOW

The “Set-up Parameters” window is used to view and adjust any of the set-up parameters. This window is selected from the “Window” menu.

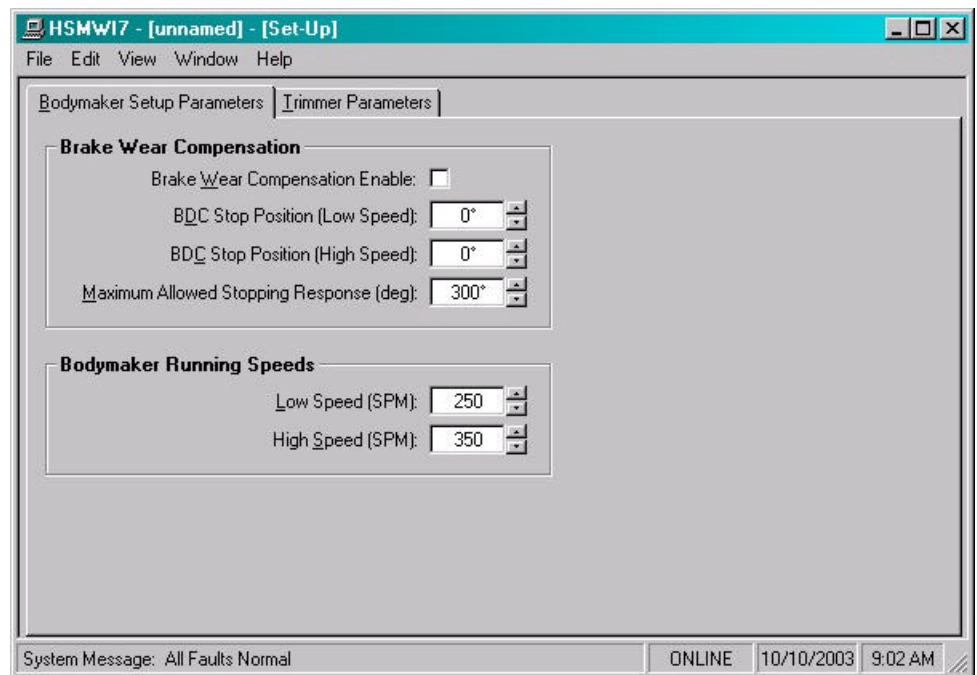

This window utilizes a “TAB” control to divide the set-up parameters into three categories, similar to that of the Keypad/Display.

SECTION 4

HSMWI7 WINDOWS BASED SET-UP PROGRAM REFERENCE

Brake Wear Compensation: This section is used to set the brake wear compensation parameters in the M4500. This section contains the following selections:

- 1) **Brake Wear Compensation Enable:** This prompt is used to enable or disable the brake wear compensation. If the compensation is to be disabled, deselect the check box. If the compensation is to be enabled, select the check box.

The HSM-WI7 incorporates a brake wear compensation or automatic BDC timing feature, which stops the press at “Back Dead Center” regardless of the actual braking response of the clutch/brake. The stopping compensation is accomplished by automatically adjusting the BDC timing signal based on the previous stop. Any overrun is detected and a new BDC timing signal is computed such that the machine will stop at the desired location on the next stop. Two BDC signals are provided: one for low speed and one for high speed. Both incorporate the brake wear compensation feature. The appropriate BDC timing signal (low or high) is adjusted based on the speed of the machine when the BDC stop was initiated.

- 2) **Desired BDC Stop Position (Low Speed):** This is the desired stopping location (in degrees) for a BDC stop at low speed when the brake wear compensation is enabled. This is typical set to 000 degrees (Back Dead Center).
- 3) **Desired BDC Stop Position (High Speed):** This is the desired stopping location (in degrees) for a BDC stop in high speed when the brake wear compensation is enabled. This is typical set to 000 degrees (Back Dead Center).
- 4) **Maximum Allowed Stopping Response (degrees):** This defines what the maximum allowed brake response is before the "Brake Response Too Long" alarm is generated. If the actual brake response (number of degrees from when the brake is activated to the position where the press ends up at rest) when a BDC stop is performed is longer than this number, the alarm is generated. If the actual brake response is less, the alarm is not generated. Set this parameter to the value where the brake response is considered too long and service to the brake should be performed (typically 270 to 300 degrees).

SECTION 4

HSMWI7 WINDOWS BASED SET-UP PROGRAM REFERENCE

Bodymaker Running Speeds: This section is used to set the bodymaker running speeds in the M4500. This section contains the following selections:

- 1) **Running Bodymaker Low Speed (SPM):** This is the speed (in strokes per minute), that the bodymaker will run when in low speed.
- 2) **Running Bodymaker High Speed (SPM):** This is the speed (in strokes per minute), that the bodymaker will run when in high speed.

Trimmer Parameters: This section is used to set the trimmer speed references in the M4500. This section contains the following selections:

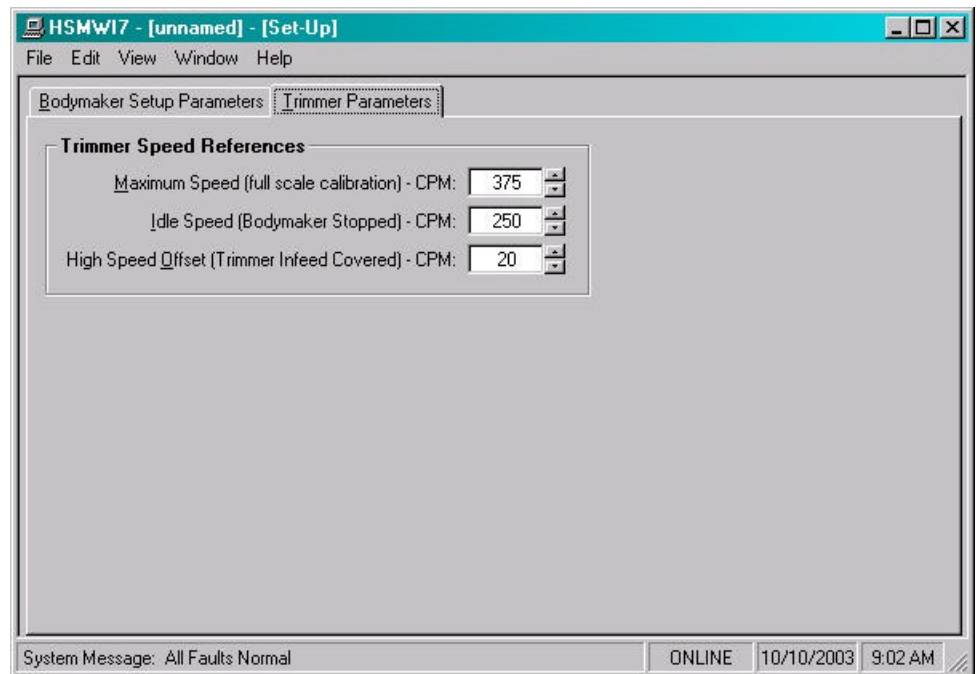

- 1) **Trimmer Maximum Speed (CPM):** The "Trimmer Maximum Speed" parameter is used to scale the 0-10VDC analog output such that when the bodymaker is running at the speed entered in "Trimmer Maximum Speed", the analog output will be at 10 volts. This is typically set to the running high speed of the Bodymaker or slightly higher.

SECTION 4

HSMWI7 WINDOWS BASED SET-UP PROGRAM REFERENCE

- 2) **Trimmer Idle Speed (CPM):** This parameter determines the speed the trimmer will run at when the bodymaker is stopped (de-clutched).

Note: When the bodymaker is running, the trimmer speed reference is proportional (as set by the "Trimmer Maximum Speed" scaling) to the speed of the bodymaker. This parameter is used to provide the speed reference when the bodymaker speed is zero.

- 3) **Trimmer High Speed Offset:** This parameter is used to modulate the speed of the trimmer as a function of cans present at the infeed of the trimmer. A high infeed sensor can be added to the trimmer infeed such that the trimmer will run at the bodymaker running speed plus the "Trimmer High Speed Offset" value. This allows the trimmer to speed up when the infeed to the trimmer backs-up and slow down once the trimmer runs the cans out.

SECTION 4

HSMWI7 WINDOWS BASED SET-UP PROGRAM REFERENCE

4.5.3 THE MACHINE TIMING WINDOW

The Machine Timing window is used to invoke the PLS programming command menus. From this window, the user can view or adjust the following parameters:

- Adjust Timing Channel setpoints.
- Set the Main Crank resolver offset.
- Clear or Recall a PLS timing channel.
- View the current PLS configuration
- Reset the PLS configuration to default settings.

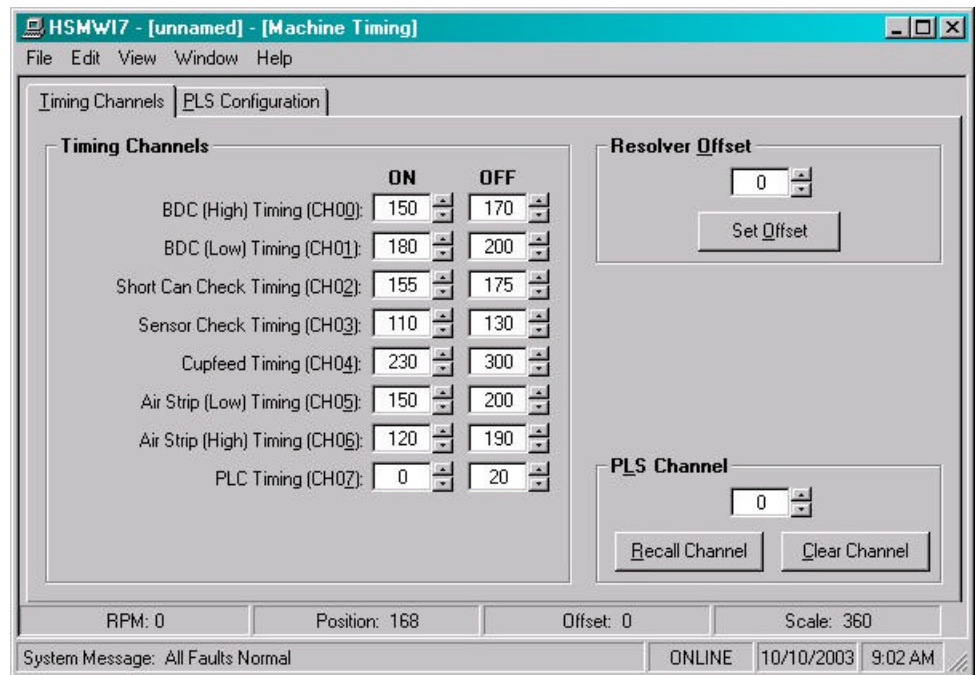

In addition, the following parameters are displayed at the bottom of this window:

RPM: This is the current speed in “Revolutions per Minute” of the main crank resolver.

Position: This is the current “Position” in degrees of the main crank resolver.

Offset: This is the current resolver offset (set in degrees).

SECTION 4

HSMWI7 WINDOWS BASED SET-UP PROGRAM REFERENCE

Scale: This is the scale factor of the resolver or the number of divisions in one revolution.

Note: The General Timing Signal Locations section provides a complete description of each timing channel signal.

Zeroing the Machine (setting the resolver offset): To set machine zero, perform the following:

- 1) Connect an RS-232 SYSdev cable from the COM port on the computer to the “PROG” port on the M4500.
- 2) From the “Window” menu, select “Machine Timing”.
- 3) From the “View” menu, select “Online Data”. The set-up program will attempt to communicate with the processor and place the system into an “Online” mode of operation.
- 4) Observe the “Position” field at the bottom of the window. Verify that as the machine is rotated forward, that the position increases linearly from 0 through 359 degrees. If not, swap the S1 and S3 leads at the resolver connector on the M4500. Then, verify that the position does indeed increase with forward movement.
- 5) Position the machine at machine zero (inch the bodymaker to back dead center BDC).
- 6) Auto zero the resolver by entering “0” in the “Resolver Offset” field and clicking the “Set Offset” command button. A message box will appear, prompting the user to confirm their choice. Select “Yes” to set the resolver offset.
- 7) The M4500 will calculate the actual offset value required to make this the “0” position. The new offset value will be displayed in the “Offset” field and the position will then read zero.

SECTION 4

HSMWI7 WINDOWS BASED SET-UP PROGRAM REFERENCE

Adjusting the Timing Channel Setpoints: To set any of the timing signal setpoints, perform the following:

Note: Any changes made to the timing channel setpoints will be saved as part of the setup data file.

- 1) Connect an RS-232 SYSdev cable from the COM port on the computer to the “PROG” port on the M4510.
- 2) From the “Window” menu, select “Machine Timing”.
- 3) From the “View” menu, select “Online Data”. The set-up program will attempt to communicate with the processor and place the system into an “Online” mode of operation.
- 4) Set all channels per section 6 – General Timing Signal Locations. Setpoints for a particular channel are either entered in the field or adjusted by using the increment/decrement controls.

Note: Only one set-point is used per channel.

- 5) If a channel needs to be “Recalled” or “Cleared”, enter the desired channel number into the “PLS Channel” field. Click the “Recall Channel” command button to recall the setpoints. Click the “Clear Channel” command button the completely clear all setpoints for the selected channel.

Note: If a channel has been cleared or the “On” and “Off” setpoints have the same setting, the set-point will be displayed as “*****”.

SECTION 4 HSMWI7 WINDOWS BASED SET-UP PROGRAM REFERENCE

Resetting the PLS Configuration: As an aid to the user the current PLS configuration is displayed in the “PLS Configuration” tab of this window. The PLS configuration should only be reset if a new module has been installed. To reset the PLS configuration, click the “Reset PLS Config” command button. This function only resets the PLS configuration to the default settings.

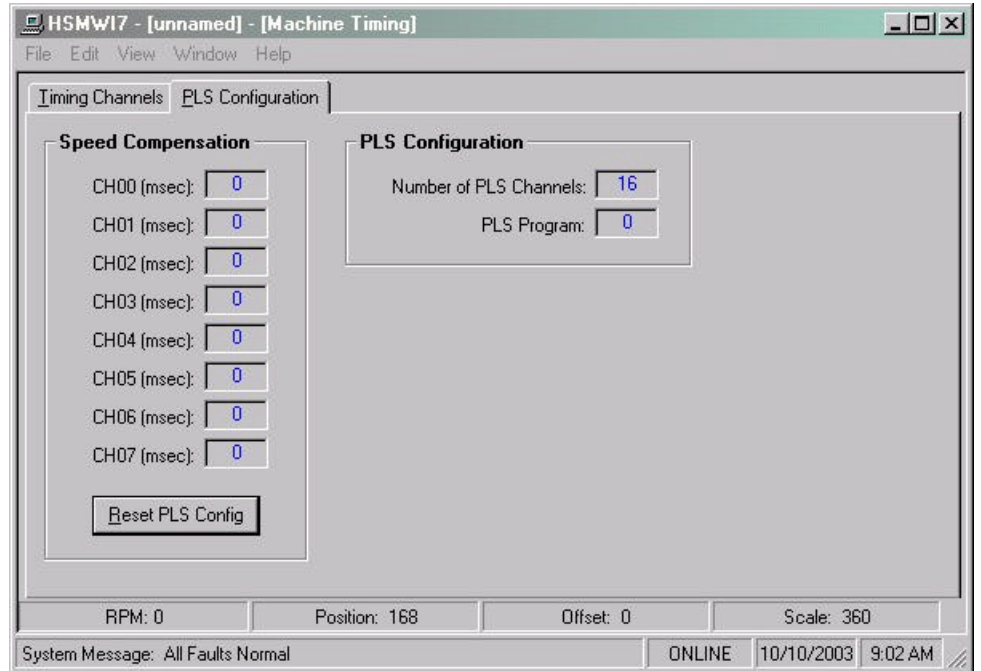

SECTION 4

HSMWI7 WINDOWS BASED SET-UP PROGRAM REFERENCE

4.5.4 THE SHIFT DATA WINDOW

The “Shift Data” window is used to view the shift data collected by the M4500. This window is selected from the “Window” menu.

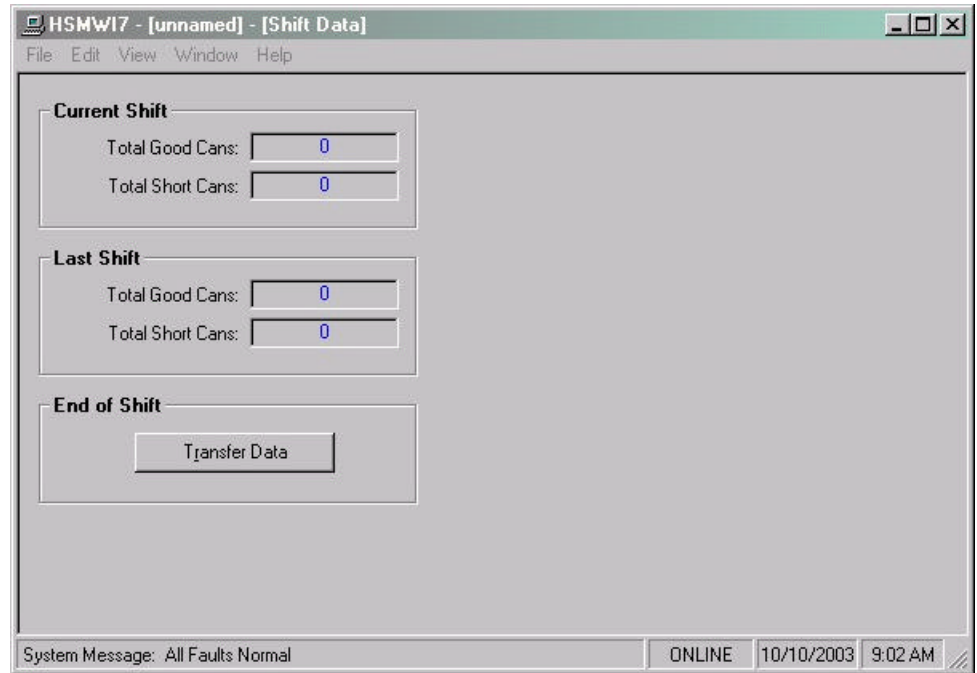

Current Shift Data: This data is the totals so far into the shift. This data is transferred to the "Last shift" at the end of either an 8 or 12 hour shift or alternatively could be done at label changes such that the data collected would be for label runs rather than complete shifts. This data can be reset by the user from this section.

Note: The “Transfer Data” command button is only active while “Online”.

- 1) **Total Good Cans:** This is the total number of good cans produced so far into the current shift. This is essentially a can counter.
- 2) **Total Short Can Faults:** This is the total number of short can faults that have occurred so far into the current shift.

SECTION 4

HSMWI7 WINDOWS BASED SET-UP PROGRAM REFERENCE

Last Shift Data: The "Last Shift" data is for the previous 8 or 12 hour shift, however the shift collection is set-up. This allows data collection and diagnostics to take place automatically over a two shift period.

4.5.5 THE I/O STATES WINDOW

The "I/O States" window is provided to display states of the inputs and outputs. The control boards, the states of the timing channels, as well as states of the M4500 are shown. This includes the interrupt inputs (IN0 and IN1), the analog I/O and the resolver. These values are displayed as read by the M4500 processor.

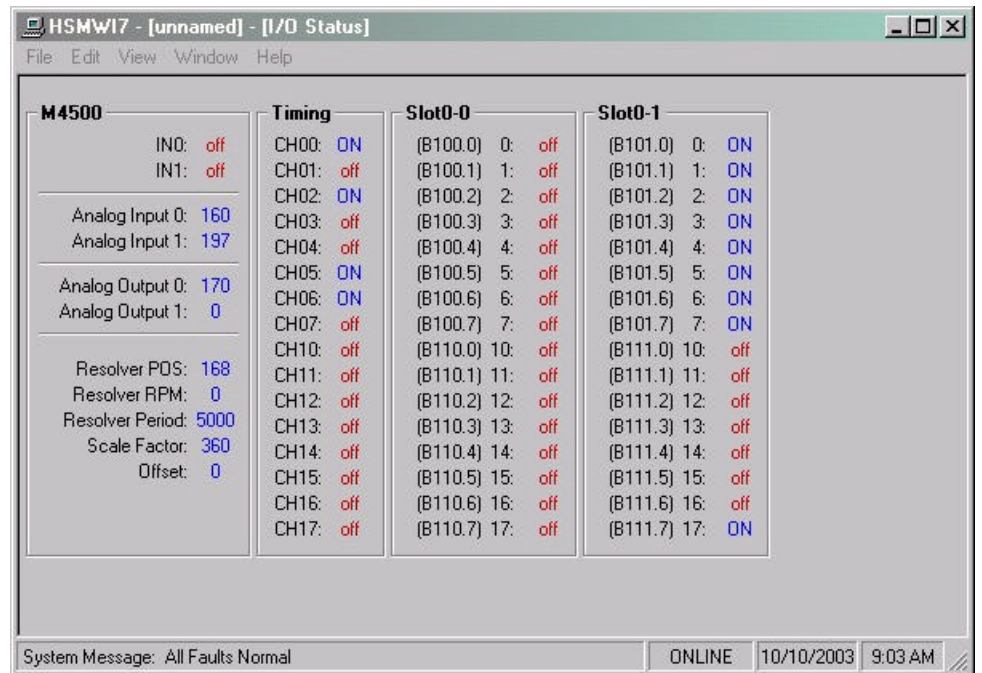

**SECTION 4
HSMWI7 WINDOWS BASED
SET-UP PROGRAM REFERENCE**

(This Page Intentionally Left Blank)

SECTION 5 HSMWI7 DOS BASED SET-UP PROGRAM REFERENCE

The DOS based “HSMWI7” set-up program is menu driven program, allowing the user to easily view data or alter set-up variables using a laptop or personal computer. In addition to setting the set-up variables, it can be used to download the application program to the module as well as download and up-load the set-up data and save it to disk. The set-up variables are used to configure and tune the HSM-WI7 to match the configuration and performance of the specific bodymaker (see section 2.8).

The main menu of the “HSMWI7” set-up program incorporates the following menu selections:

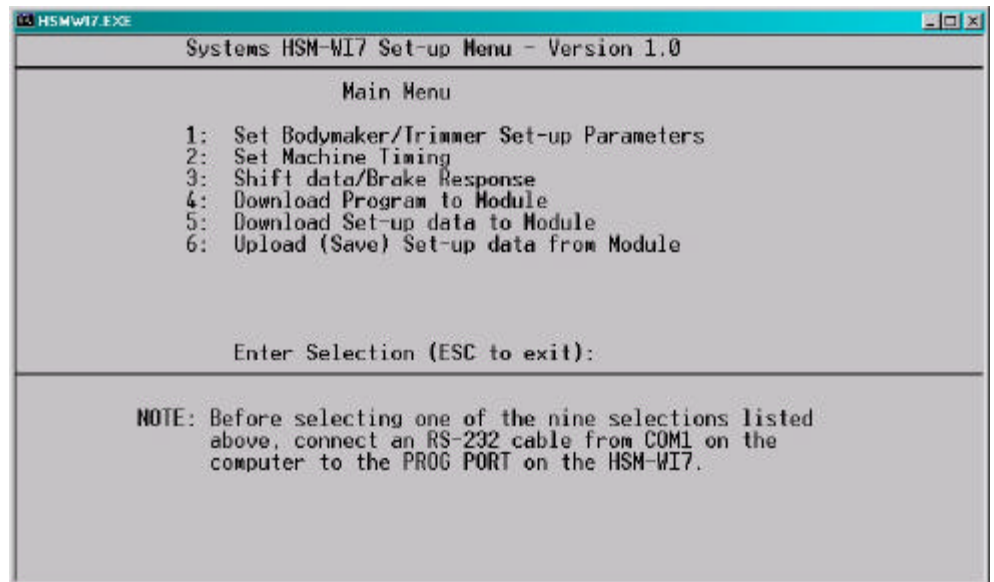

Note: The “HSMWI7” program is an on-line communications program used to interface with the M4500 module. The data displayed in the menus and set in the menus is communicated directly to the module. Therefore, prior to selecting any of the above selections, make sure an RS-232 cable is connected from the COM port on the computer running “HSMWI7” to the “PROG” port on the HSM-WI7.

The following sections are a complete description of the “HSMWI7” selections and menus.

SECTION 5 HSMWI7 DOS BASED SET-UP PROGRAM REFERENCE

5.1 SET BODYMAKER/TRIMMER SET-UP PARAMETERS

This selection is used to set the various set-up parameters in the HSM-WI7. When selected, the “Bodymaker/Trimmer Set-up Parameters” menu is invoked.

The “Bodymaker/Trimmer Set-up Parameters” menu contains the following selections:

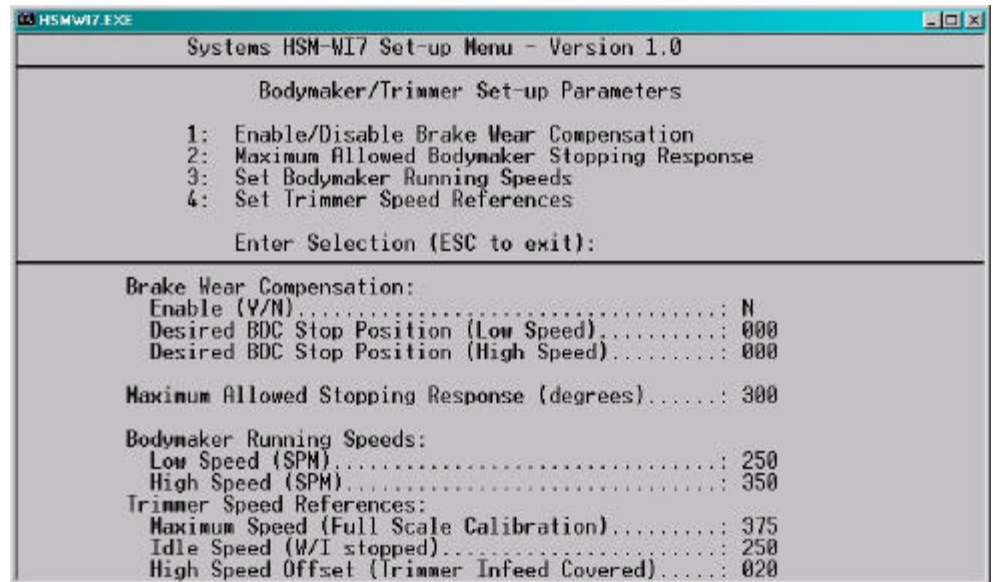

The following selections set the corresponding parameters:

5.1.1 ENABLE/DISABLE BRAKE WEAR COMPENSATION

Brake Wear Compensation Enable? (0=No, 1=Yes): This prompt is used to enable or disable the brake wear compensation. If the compensation is to be disabled, enter “0” and press <ENTER>. If the compensation is to be enabled, enter “1” and press <ENTER>.

Desired BDC Stop Position (Low Speed): This is the desired stopping location (in degrees) for a BDC stop in low speed when the brake wear compensation is enabled. This is typical set to 000 degrees (Back Dead Center).

SECTION 5 HSMWI7 DOS BASED SET-UP PROGRAM REFERENCE

Desired BDC Stop Position (High Speed): This is the desired stopping location (in degrees) for a BDC stop in high speed when the brake wear compensation is enabled. This is typical set to 000 degrees (Back Dead Center).

5.1.2 MAXIMUM ALLOWED B/M STOPPING RESPONSE

Maximum Allowed Stopping Response (degrees): This defines what the maximum allowed brake response is before the “Brake Response Too Long” alarm is generated. If the actual brake response (number of degrees from when the brake is activated to the position where the press ends up at rest) when a BDC stop is performed is longer than this number, the alarm is generated. If the actual brake response is less, the alarm is not generated. Set this parameter to the value where the brake response is considered too long and service to the brake should be performed (typically 270 to 300 degrees).

5.1.3 SET BODYMAKER RUNNING SPEEDS

Running Bodymaker Low Speed (SPM): This is the speed (in strokes per minute) that the bodymaker will run when in low speed.

Running Bodymaker High Speed (SPM): This is the speed (in strokes per minute) that the bodymaker will run when in high speed.

SECTION 5

HSMWI7 DOS BASED

SET-UP PROGRAM REFERENCE

5.1.4 SET TRIMMER SPEED REFERENCES

Trimmer Maximum Speed (CPM): The “Trimmer Maximum Speed” parameter is used to scale the 0-10VDC analog output such that when the bodymaker is running at the speed entered in “Trimmer Maximum Speed”, the analog output will be at 10 volts. This is typically set to the running high speed of the Bodymaker or slightly higher.

Trimmer Idle Speed (CPM): This parameter determines the speed the trimmer will run at when the bodymaker is stopped (de-clutched).

Note: When the bodymaker is running, the trimmer speed reference is proportional (as set by the “Trimmer Maximum Speed” scaling) to the speed of the bodymaker. This parameter is used to provide the speed reference when the bodymaker speed is zero.

Trimmer High Speed Offset: This parameter is used to modulate the speed of the trimmer as a function of cans present at the infeed of the trimmer. A high infeed sensor can be added to the trimmer infeed such that the trimmer will run at the bodymaker running speed plus the “Trimmer High Speed Offset” value. This allows the trimmer to speed up when the infeed to the trimmer backs-up and slow down once the trimmer runs the cans out.

SECTION 5 HSMWI7 DOS BASED SET-UP PROGRAM REFERENCE

5.2 SET MACHINE TIMING

The Set Machine Timing selection is used to invoke the PLS programming command menus (these are the same menus used in SYSdev to program the PLS section of the HSM-WI7). When selected, the PLS programming main development menu will be invoked using the default “WI7TMG” channel set-point file.

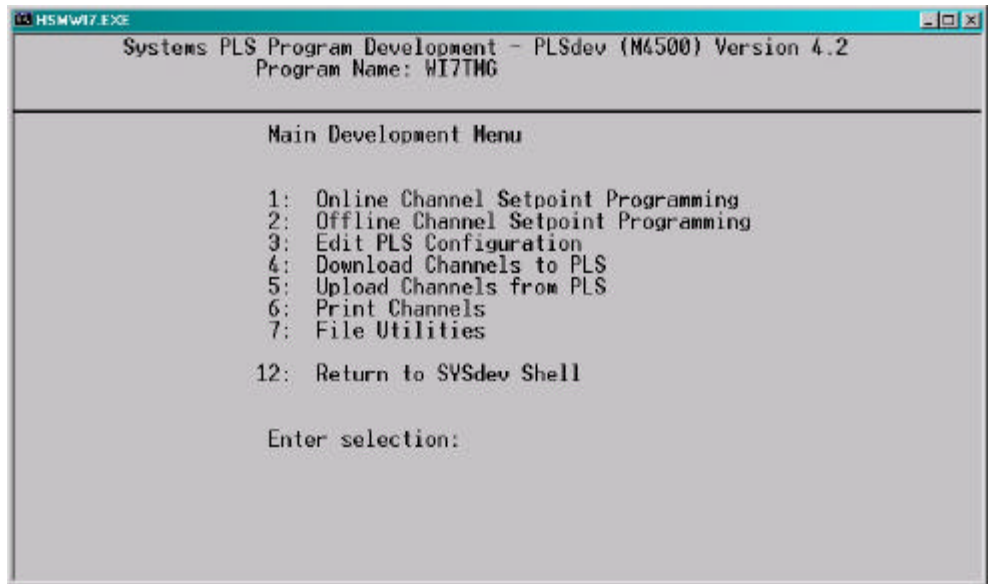

From this menu, the user can zero the machine (set the resolver offset) and adjust the timing signal set-points. The following sections describe how to perform these functions, section 6 provides a complete description of each timing signal.

Note: Prior to selecting the Machine Timing selection, make sure the RS-232 cable is connected from the COM port on the computer to the PROG PORT on the HSM-WI7.

SECTION 5 HSMWI7 DOS BASED SET-UP PROGRAM REFERENCE

5.2.1 ZEROING THE MACHINE

To set the machine zero (resolver offset) perform the following:

- 1) Select the “2: Set Machine Timing” selection from the HSM-WI7 set-up program main menu.
- 2) Select “1: Online Channel Setpoint Programming” from the Main Development menu.

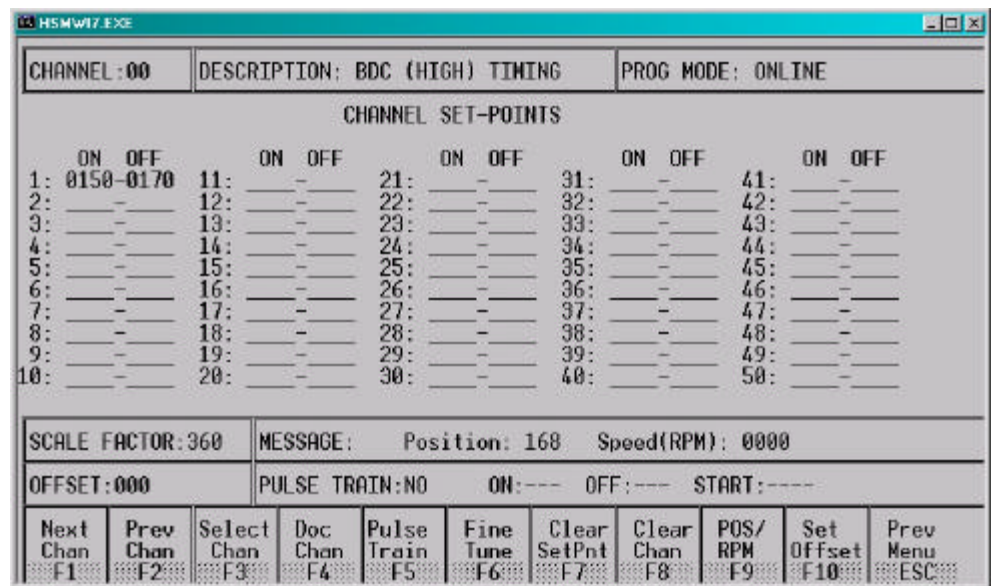

- 3) Select “F9: POS/RPM” and observe the “POS:” field. Verify that as the machine is rotated forward (either inching or barred) that the position increases linearly from 0 through 359. If not, swap the S1 and S3 leads of the resolver at the HSM-WI7 resolver connector. Then verify that the position then indeed does increase with forward movement. Press <ESC> to exit the “POS/RPM” update.
- 4) Position the machine at back dead center.
- 5) Auto zero the resolver by selecting “F10: Set Offset”. Enter “0” in the offset field and press <ENTER>. The HSM-WI7 will calculate the actual offset value required to make this the 000 position and will display this number in the offset field. The position will now read 0.

SECTION 5 HSMWI7 DOS BASED SET-UP PROGRAM REFERENCE

- 6) Exit back to the PLS Main Development menu by pressing <ESC>. Exit back to the “HSMWI7” set-up main menu by pressing <ESC>again.

5.2.2 ADJUSTING THE TIMING CHANNEL SET-POINTS

To set or alter any of the timing signal set-points, perform the following:

- 1) Select the “2: Set Machine Timing” selection from the HSM-WI7 set-up program main menu.
- 2) Select “1: Online Channel Setpoint Programming” from the Main Development menu.
- 3) Set all channels per section 6. Set-points are entered for a particular channel simply by typing in the set-point in the form XXX-YYY<ENTER> in the first set-point of the given channel

Note: Up to 50 set-points may be entered for any channel. However, for the bodymaker only one set-point is used per channel and this should be entered in the number 1 set-point.

The XXX is the location the set-point will turn “on” while YYY is the location where the set-point will turn “off”. Use the PgUp, PgDn, F1:Next Chan, or F2: Prev Chan keys to select the desired channel for programming.

- 4) Once all channels are programmed, press <ESC> to exit back to the PLS Main Development Menu. Press <ESC> again to exit back to the “HSMWI7” set-up main menu. The new channels will be saved both in the module and in the “WI7TMG” file on the hard drive.

SECTION 5 HSMWI7 DOS BASED SET-UP PROGRAM REFERENCE

5.3 SHIFT DATA/BRAKE RESPONSE

This selection is used to view the Current Shift data, Last Shift data, and the Low and High Speed Brake Responses. When selected, the “Shift Data/Brake Response” menu is invoked.

The following data is displayed in the “Shift Data/Brake Response” menu:

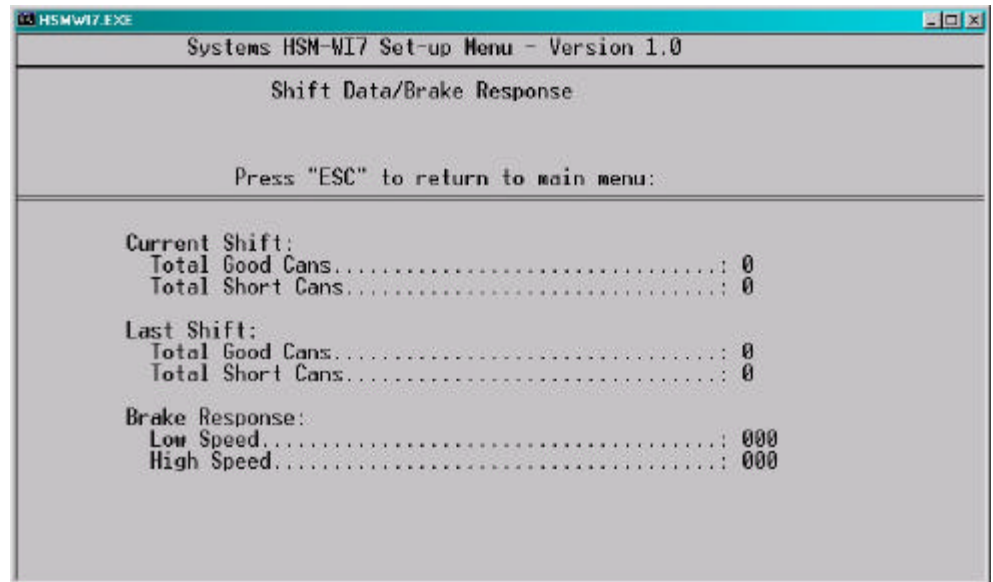

Current Shift - Total Good Cans: This is the total number of good cans produced so far into the current shift. This is essentially a can counter.

Current Shift - Total Short Can Faults: This is the total number of short can faults that have occurred so far into the current shift.

Last Shift: The "Last Shift" data is identical to the current shift data except it is for the previous 8 or 12 hour shift or previous label run, however the shift collection is set-up. This allows data collection and diagnostics to take place automatically over a two shift period

Note: The current shift data is transferred to the “Last shift” data when the end of shift input transfers from a “0” to a “1”. This data cannot be reset either from this menu or by the operator, only at the end of shift transition.

SECTION 5 HSMWI7 DOS BASED SET-UP PROGRAM REFERENCE

Lo Speed Brake Response (degrees): This is the number of degrees from the when the clutch was de-activated (at the BDC (Lo) timing) to where the bodymaker crankshaft came to rest when a BDC stop was performed at Low speed. This can be used to determine the general condition of the brake and whether servicing of the brake is required.

Hi Speed Brake Response (degrees): This is the number of degrees from the when the clutch was de-activated (at the BDC (hi) timing) to where the bodymaker crankshaft came to rest when a BDC stop was performed at high speed. This can be used to determine the general condition of the brake and whether servicing of the brake is required.

Note: The brake response of the brake for both high and low speeds is updated after each BDC stop.

SECTION 5

HSMWI7 DOS BASED SET-UP PROGRAM REFERENCE

5.4 DOWNLOAD PROGRAM TO MODULE

This selection is used to download the HSMWI7 application program to the HSM-WI7 module. This should only be performed when replacing the module or when the program has been changed. To download the program, perform the following:

Note: Program download cannot be performed while the bodymaker is running. All outputs on the HSM-WI7 are turned “off” and no program execution is performed. The bodymaker should therefore be stopped before the download takes place.

- 1) Connect the RS-232 cable from the COM port on the computer to the “PROG” port on the HSM-WI7.
- 2) Select “4: Download Program to Module” from the Main Menu. The current program ident, revision, and checksum for both the program on disk and already loaded in the module will be displayed. A prompt will be displayed asking to continue or abort. To continue, press any key except the <ESC> key. To abort, press the <ESC> key. If a prompt stating that the “HSMWI7” file could not be opened is displayed, then the “HSMWI7” application program is not installed in the current directory.
- 3) Once program download is initiated, HSM-WI7 program execution will cease, the current address being downloaded will be displayed, and the “RUN” LED on the module will flash continuously.
- 4) Once the download is complete, the “RUN” LED on the module will illuminate solid and program execution in the HSM-WI7 will resume. Press any key to return back to the “HSMWI7” main menu.
- 5) This selection can also be used to verify the program ident, revision, and checksum without downloading the program. Perform steps 1 thru 3 above but instead of initiating the download in step 3, simply press the <ESC> key to abort the download once the ident, revision, and checksum have been displayed.

SECTION 5 HSMWI7 DOS BASED SET-UP PROGRAM REFERENCE

5.5 DOWNLOAD SET-UP DATA TO MODULE

This selection is used to download the previously uploaded (saved) set-up variables to the HSM-WI7 module. This should only be performed when replacing the module.

Note: The set-up data consists of the bodymaker and trimmer set-up parameters. Timing channel set-points are not stored as part of the set-up data, these are stored in the “WI7TMG” file. To download the set-up data, perform the following:

- 1) Connect the RS-232 cable from the COM port on the computer to the “PROG” port on the HSM-WI7.
- 2) Select “5: Download Set-up data to Module”. A prompt will be displayed asking to continue or abort. To continue, press any key except the <ESC> key. To abort, press the <ESC> key.
- 3) Once data download is initiated, the current address being downloaded will be displayed.

Note: Program execution is not ceased therefore data download can be performed while the machine is running.

- 4) Once download is complete, press any key to return to the main menu.

SECTION 5

HSMWI7 DOS BASED

SET-UP PROGRAM REFERENCE

5.6 UPLOAD (SAVE) SET-UP DATA FROM MODULE

This selection is used to save the set-up variables from the HSM-WI7 module to the hard drive (current directory selected). This should be performed anytime any of the set-up variables have been changed.

Note: When the set-up variables are changed, they are changed directly in the module, not on the file in the computer. By uploading (saving) the set-up variables to disk, they can be downloaded to the module in the event the module must be replaced.

The set-up data consists of the bodymaker and trimmer set-up parameters. Timing channel set-points are not stored as part of the set-up data, these are stored in the "WI7TMG" file. To upload the set-up data, perform the following:

- 1) Connect the RS-232 cable from the COM port on the computer to the "PROG" port on the HSM-WI7.
- 2) Select "6: Upload (Save) Set-up data from Module". A prompt will be displayed asking to continue or abort. To continue, press any key except the <ESC> key. To abort, press the <ESC> key.
- 3) Once data upload is initiated, the current address being uploaded will be displayed.

Note: Program execution is not ceased therefore data upload can be performed while the machine is running.

- 4) Once upload is complete, press any key to return to the main menu.

SECTION 6 GENERAL TIMING SIGNAL LOCATIONS

The following is a general description of the timing signals and the locations they should be set at:

CH00: BDC (High) Timing: This signal is used to de-activate the clutch for a BDC stop at high speed.

Note: The leading edge is used to de-activate the clutch, thus the width of the signal is not critical (generally set 20 degrees wide).

When the brake wear compensation is enabled, this signal is adjusted automatically by the HSM-WI7. If the brake wear compensation is disabled, this signal must be set manually. In this case it should be set such that the press stops at back dead center for a BDC stop at high speed.

CH01: BDC (Low) Timing: Same as the BDC (High) timing (CH00) except used when the machine is running in low speed.

CH02: Short Can Timing: This signal is used to verify the length of the can and verify that the can is good. The short can sensor must “see” can the entire time this signal is “on” to prevent a short can alarm. This signal is generally set in the range of “on” at 150 to 160 and “off” at 170 to 175”.

CH03: Sensor Check Timing: This signal is used to verify that the short can sensor does not fail “on”. The short can sensor must be “off” the entire time this signal is “on” in order to prevent a “die sensor fail” alarm. This signal is generally programmed to be “on” just prior to the punch emerging from the die set on the forward stroke (typical “on” at 110 and “off” at 130).

SECTION 6

GENERAL TIMING

SIGNAL LOCATIONS

- CH04: Cupfeed Timing:** This signal is used to activate the cupfeed “on” when enabled and back “off” when disabled. The leading edge of this signal is used to activate the solenoid “on” while the trailing edge is used to activate it “off”. The “on” set-point is generally set such that when the cupfeed is opened, the cup will drop onto the high part of the rotary cam. The “off” set-point is generally set such that the cupfeed will close such that the cup is caught with-out causing damage to the cup that is retained. This signal is generally set “on” at 230 to 250 and “off” at 280 to 320.
- CH05: Air Strip (Low) Timing:** This signal is used to activate the air strip solenoid when the machine is running in low speed. The air strip is “on” for the entire window that CH05 is “on” while the machine is running with the cupfeed open. This signal is generally set “on” about 140 degrees and then set “off” at about 200.
- CH06: Air Strip (High) Timing:** Same as the Air Strip (Low) timing (CH05) except used when the machine is running in high speed. This is generally set “on” about 120 degrees and then “off” at about 190.
- CH07: PLC Timing:** This is a general purpose timing signal provided as an output which can be input to the host PLC and used for whatever purpose desired by the host PLC. This channel is not used by the HSM-WI7.
- CH10: Motion Timing:** This is a pulse train set “on” for 30 degrees and then set “off” for 30 degrees through-out the entire channel.

**SECTION 7
RECOMMENDED SPARE
PARTS**

The Following are recommended spares for the HSM-WI7. These parts are available through Systems Engineering Assoc. Inc.

<u>Quantity</u>	<u>Part Number</u>	<u>Description</u>
1ea.	HSM-WI7	Standun Bodymaker High Speed Logic Module